

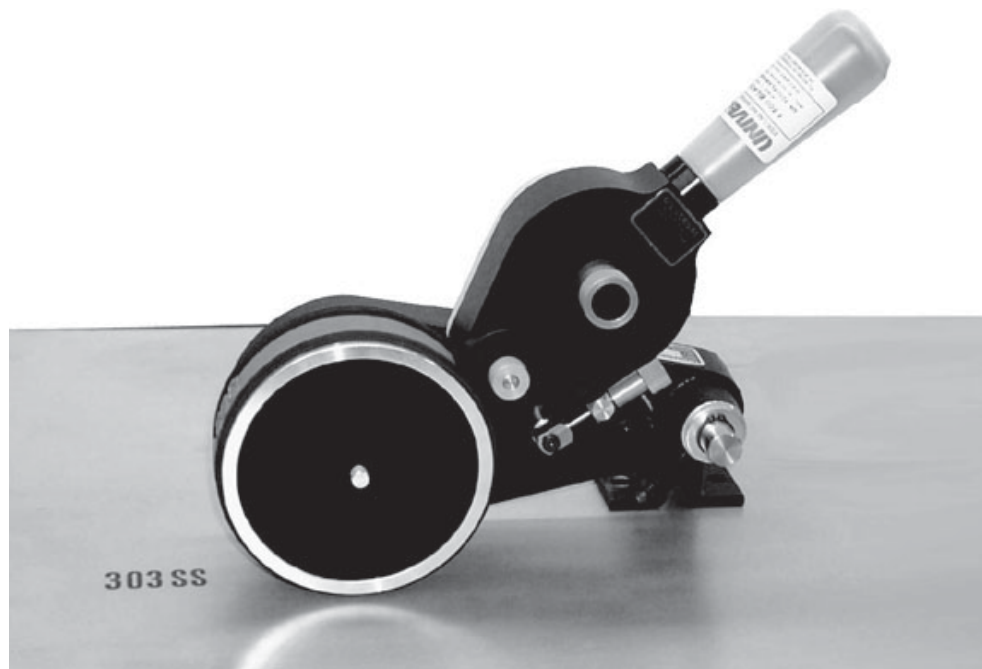

OWNER'S MANUAL

**NON-POROUS
CONVEYOR LINE PRINTERS
ALL MODELS**

INSTALLATION - OPERATION - MAINTENANCE



UNIVERSAL STENCILING & MARKING SYSTEMS, INC.

P.O. BOX 871 - ST. PETERSBURG, FLORIDA 33731 USA

PH: (727) 894-3027 FAX: (727) 821-7944

E-Mail: sales@universal-marking.com Website: www.universal-marking.com

NPCLP-09048

IMPORTANT NOTE

UNIVERSAL products are manufactured to exacting standards and every available step has been taken to assure your complete satisfaction. It is most important, for best results, that you read and carefully follow the instructions contained in this manual. Failure to do so may result in unsatisfactory performance, damage to the equipment and personal injury.

PREFACE	3
SPECIFICATIONS	
CLP-100 Series	4
CLP-200 Series	5
Indexing and Non-Indexing Models	6
Mounting Configurations	6
Printing Dies	7
Ink Rolls	8
QUICK START	
Installing the Inking System Assembly	9
Installing the Pre-Inked Roll	10
Installing the Printing Dies	14
Adjusting the Ink Roll Eccentric	15
BASIC PRINCIPLES OF OPERATION	
Inking System	16
Using the 4 Oz. Reservoir Ink Cartridges	16
Selecting an Appropriate Ink	17
Ink Drying Time Considerations	18
WEB PRINTING	
Mounting the Coder	20
Special Web Printing Applications	21
Printing on Narrow Web Materials	21
Printing directly on Master Rolls	21
Gang Mounting	22
CARTON PRINTING	
Carton Alignment	23
Die Positioning for Indexing Applications	25
MAINTENANCE	
Pre-Inking a New Ink roll	27
Cleaning the Transfer Roll	28
Cleaning the Coder	28
Cleaning the Printing Dies	29
Mounting Configuration Conversion	30
Replace Print Drum Index Springs	34
Removing and Replacing Index Block "B"	35
Inking System Assembly	37
PARTS DIAGRAMS & PARTS LISTS	39

- LIMITED WARRANTY -

UNIVERSAL Non-Porous Conveyor Line Printers are guaranteed to be free from defects in materials and workmanship for a period of 90 days from the date of purchase. Components found to be defective during this time will be repaired free of charge if returned to the factory. Damage resulting from use of improper inks, improper installation, or operation is not covered under the scope of this warranty. For warranty service please contact our Customer Service Department.

PREFACE

Printing on non-porous materials has always been a major problem in industrial applications. The high degree of maintenance required to keep conventional coders operating with solvent based inks has made many companies opt for manual marking as a cost effective alternative. With UNIVERSAL Non-Porous Coders, printing on non-porous materials can be accomplished with the same relative ease as printing on porous materials. This breakthrough in Non-Porous coder design opens up in-plant printing opportunities which previously were regarded as too costly to consider.

Inks used to print on porous materials dry through absorption into the material being printed. Inks used to print on non-porous materials dry through the rapid evaporation of the ink solvents after the print is applied. Since the ink solvents must evaporate very rapidly on the printed material, they also evaporate very rapidly from the ink rolls and ink wells of conventional coders therefore requiring constant maintenance.

The proprietary design of the UNIVERSAL Non-Porous Inking System effectively eliminates the rapid evaporation of the ink solvents from the ink roll and additionally provides for convenient automatic re-inking of the roll without interrupting the printing process. After many months of design engineering and field testing, the Non-porous Conveyor Line Printer is both simplistic in design and extremely effective in operation. The relatively low cost of this system makes in-plant printing of all types of non-porous materials a practical reality. The following pages of this manual explain the installation, operation and maintenance of Non-Porous Conveyor Line Printer and are the key to trouble free non-porous printing.

QUICK START **PAGES 9 THRU 15**

This manual was written with a full understanding that very few people like to read manuals or have the time to do so. To accommodate those who have little time to spare, we have included a Quick Start section which will get your coder operating in just a few minutes.

To keep your coder operating properly, it is important to read and understand the Basic Principles of Operation section which explains the basic operation of the Non-Porous Inking System.

CODER SPECIFICATIONS

The specification section includes drawings with the basic dimensions of the coders, the net weights, maximum die capacities, maximum print width and print drum circumferences. This section also lists the specifications for the printing dies and an explanation of the Indexing and Non-Indexing models and the various mounting configurations.

SPECIFICATIONS

CONVEYOR LINE PRINTER SPECIFICATIONS TOP MOUNT SERIES

Model Shown: CLP-100NI-NPRT

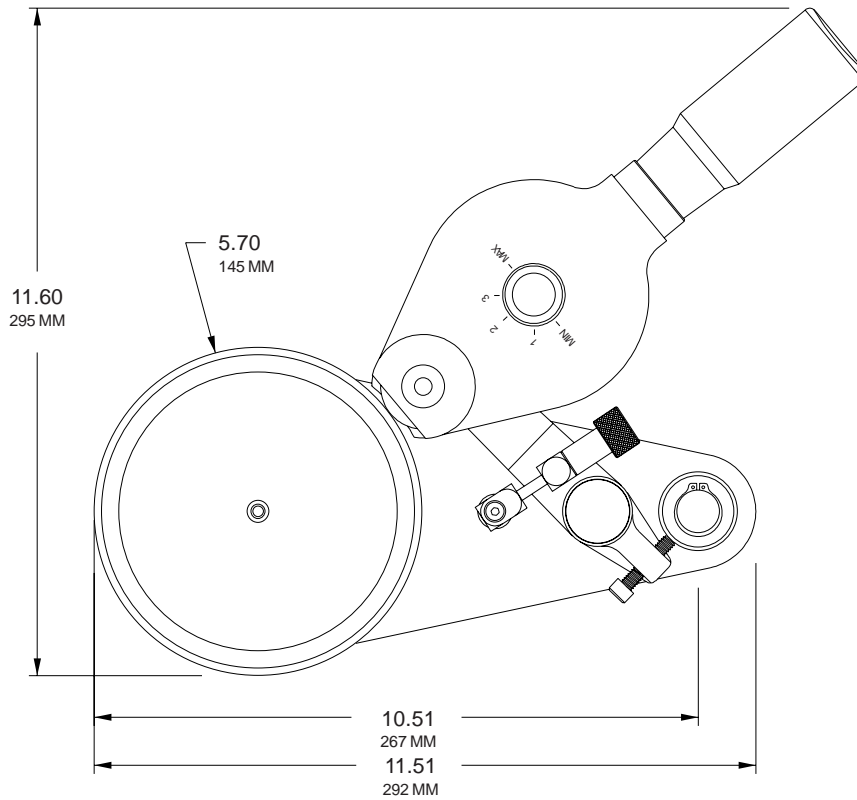
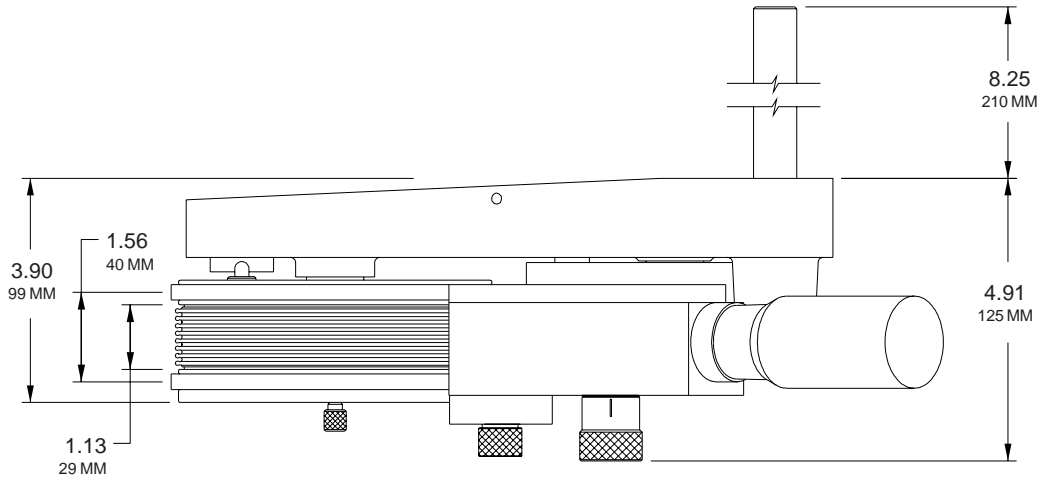

NET WEIGHT:

MAXIMUM DIE SIZE - US STANDARD:

MAXIMUM DIE SIZE - METRIC CODERS ONLY:

PRINT DRUM CIRCUMFERENCE:

10 LBS. - 12 OZS. (4.88 KG.)

7/8" (7 RIBS) X 16-15/16" LENGTH

23.8 MM (7 RIBS) X 430.2 MM LENGTH

APPROXIMATELY 18" (457 MM) MEASURED AT DIE FACE

SPECIFICATIONS

CONVEYOR LINE PRINTER SPECIFICATIONS SIDE MOUNT SERIES

Model Shown: CLP-200NI-NPLS

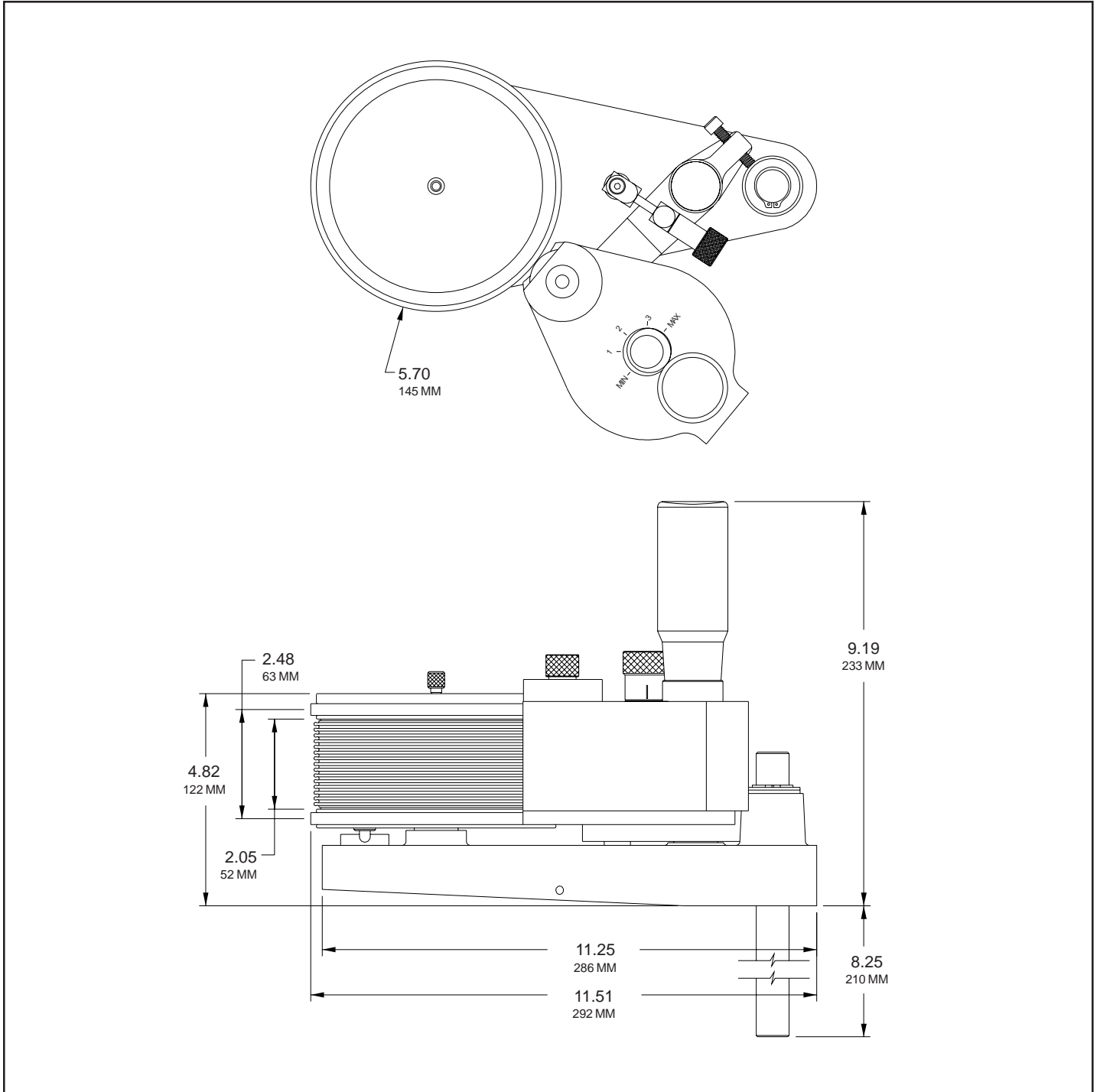

NET WEIGHT:

MAXIMUM DIE SIZE - US STANDARD:

MAXIMUM DIE SIZE - METRIC CODERS ONLY:

PRINT DRUM CIRCUMFERENCE:

11 LBS. -5 OZS. (5.13 KG.)

1-7/8" (14 RIBS) X 16-15/16" LENGTH

49.2 MM (13 RIBS) X 430.2 MM LENGTH

APPROXIMATELY 18" (457 MM) MEASURED AT DIE FACE

SPECIFICATIONS

INDEXING AND NON-INDEXING MODELS

Universal Non-Porous Conveyor Line Printers are available in both indexing and non-indexing models.

Indexing coders contain a print drum spring return mechanism which provides print registration capabilities when carton printing (see Figure 1). As the trailing edge of a carton passes the coder, the print drum automatically rotates back to the same starting or “home” position. There must be adequate space between cartons at any given line speed for this mechanism to work properly. Printing with an indexing coder will allow the imprint on each carton to be registered in the same position relative to the leading edge of the carton. The code will repeat every 18" down the length of the carton.

Non-indexing coders have print drums which simply rotate on bearings with no spring return mechanism. These coders are normally used for web printing applications where the print drum stays in contact with the web at all times. If used in carton printing applications, when the trailing edge of a carton passes the coder, the print drum rotation stops at a random position. When the next carton engages the print drum, the code will begin printing at a random position relative to the leading edge of the carton and repeat the code every 18" down the length of the carton.

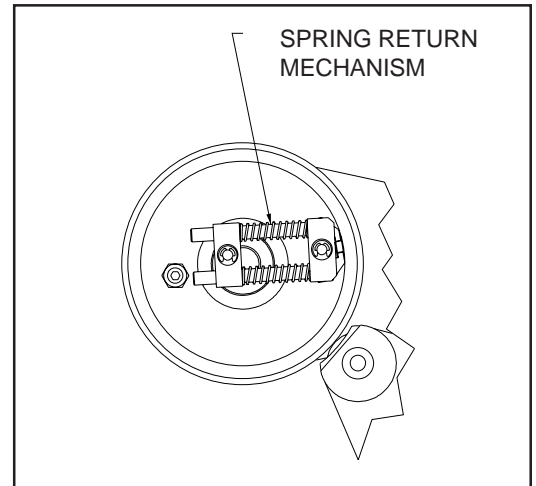

FIGURE 1

MOUNTING CONFIGURATION

The mounting configuration of a coder is determined by how the machine is designed to be mounted in relation to the product and its movement. All references to mounting configuration are made as though you are viewing the production line with the product moving away from you. Universal Conveyor Line Printers are available from the factory in 4 different mounting configurations as shown in Figures 2 and 3.

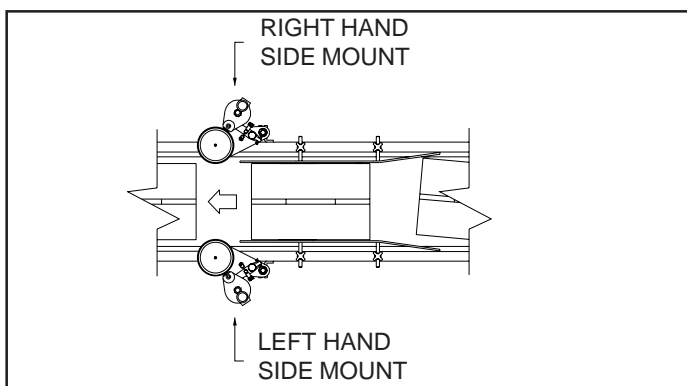

FIGURE 2

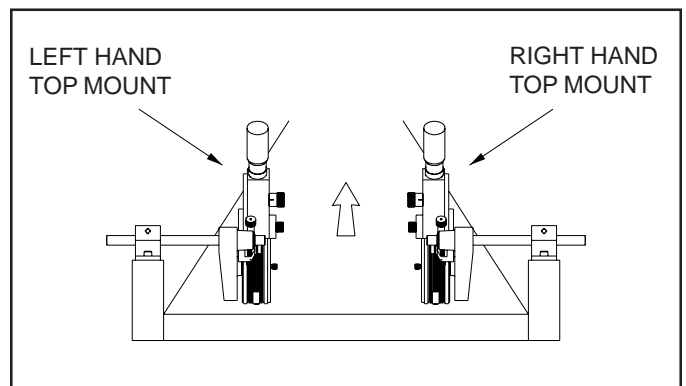

FIGURE 3

Note: Due to the symmetrical design of the Inking System on the Non-Porous Conveyor Line Printer, the Right Hand and Left Hand mounting configurations are field convertible. Due to the location of the ports for the 4 Oz. Reservoir Ink Cartridges, Top Mount and Side Mount orientations cannot be field converted and must be properly specified when ordering.

SPECIFICATIONS

RIBtype® PRINTING DIES

Universal Non-Porous Coders are designed to use Universal RIBtype® printing dies which have a molded rib backing. The ribs on the back of the die snap into mating ribs in the Drum Cover on the print drum as shown in Figure 4.

The standard printing dies are available in sets with many sizes and character styles. The sets are a combination of individual alphabetic and numeric characters or in sets containing numeric characters only. These character sets or “sorts” can be used to make up text messages and code numbers as necessary.



FIGURE 4

Printing dies are also available in “logo” form in which a complete text message, company logos or trademarks are produced on a single piece of rib backed rubber. These “logo” dies are photographically reproduced from black and white art work. Due to their unitized construction, these dies generally produce better print quality and are much faster to change in the field. For details on ordering custom logo dies, please contact our Customer Service Department.

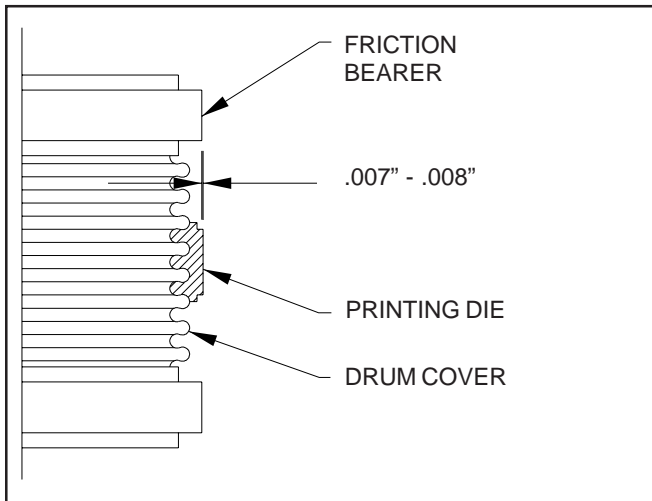

FIGURE 5

Printing dies are manufactured to precision thickness tolerances which are very critical to the performance of these coders. When installed, the face of the printing die should extend only .007" - .008" beyond the radius of the Friction Bearers as shown in Figure 5. Using dies that do not meet the design specifications will result in poor print quality and possible damage to the transfer roll.

Although there are several competitive rib backed die systems available, it is very important to note that they are not all made to the same rib spacing or thickness specifications and they are not interchangeable.

CODER MODELS DESIGNED FOR METRIC RIBtype® PRINTING DIES

Universal also offers Metric RIBtype® die systems for use in countries where metric character sizes are the standard. The Metric dies are thicker and the rib spacing differs slightly from the standard printing dies therefore the two versions are not compatible. To accommodate the differences, the print drums for Metric dies are machined to a slightly different diameter from the U.S. versions.

The coder model numbers on Metric coders will have a “-T” suffix and the Metric Drum Covers have a distinct pink color.

SPECIFICATIONS

INK ROLLS

Universal offers two ink roll options for the Non-Porous Conveyor Line Printers each with unique characteristics which will help determine the suitability for a specific printing application. The coders are designed to accommodate both types of ink rolls without modification. A detailed review of your printing requirements will determine the best choice of ink rolls for your particular application.

XF NEOPRENE INK ROLLS

Universal's XF Neoprene Ink Rolls are a re-inkable roll which can be used with a variety of alcohol or glycol base inks. These rolls are normally supplied in a dry condition with the coder and require **pre-inking** prior to installation. Pre-inked rolls are available from the factory and are recommended for first time users.

During production printing, when the ink capacity of the roll is depleted, installing a 4 Oz. Reservoir Ink Cartridge in the coder's reservoir Bottle Port will re-ink the roll automatically as production continues.

In high speed web printing applications, Universal's #100 Inks provide drying times of approximately 2 seconds at 75 Degree F. (24 Deg. C) ambient temperature. Many other inks, both dye and pigment based, can be used in these ink rolls to meet the specific application requirements. Refer to the Basic Principles of Operation section on Page 16 for more information on selecting an appropriate ink.

TYPE MT INK ROLLS

Universal's Type MT Ink Rolls are disposable pre-inked rolls which are available in a variety of fast drying colors. The MT Ink Rolls provide excellent color density and adhesion on most materials and an average yield of just under 500,000 impressions before replacement is necessary. Since these rolls are **not re-inkable**, all references in the manual regarding the use of 4 Oz. reservoir Ink Cartridges should be disregarded when using these rolls on your coder. The ability to operate the coder without a Reservoir Ink Cartridge makes the MT Rolls particularly well suited for applications requiring printing on the bottom of web materials.

The Type MT Ink Rolls provide drying times between 4 - 7 seconds at 75 Degree F. (24 Deg. C) ambient temperature. The added convenience and simplicity of using the Type MT Ink Rolls makes them an ideal choice when production operators have little time to monitor the inking system.



FIGURE 6



FIGURE 7

QUICK START

INSTALLING THE INKING SYSTEM ASSEMBLY

Your new Non-Porous Conveyor Line Printer was fully assembled and adjusted at the factory before final inspection. In order to minimize the size of the shipping cartons used to package these machines, the Non-Porous Inking System Assembly was removed from the Pivot Arm and must be reinstalled before operation.

- 1 -To install the Inking System Assembly “A” remove the (2) Mounting Screws “B” from the bottom of the assembly.**

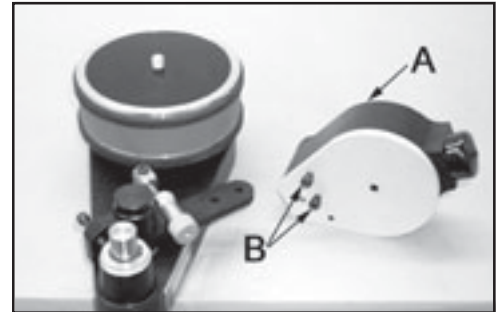

FIGURE 8

- 2 -Loosen the Pivot Arm Adjusting Knob “C” and rotate the Pivot Arm “E” away from the Print Drum “D” slightly.**

This will allow the Inking System to be installed without contact interference with the print drum.

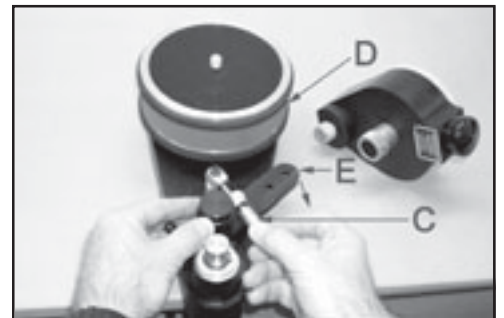

FIGURE 9

- 3 -Position the Inking System Assembly “A” on top of the Pivot Arm “E” and align the two holes in the Inking System with the matching holes in the Pivot Arm. Reinstall the two Mounting Screws “B”.**

Thread the screws in all the way but do not tighten.

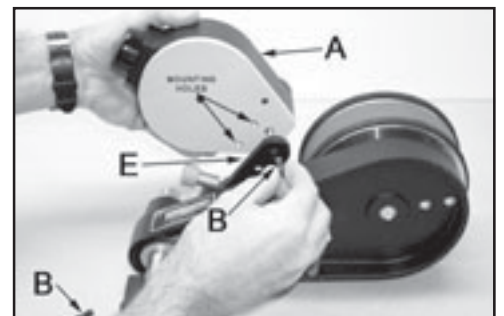

FIGURE 10

- 4 -Rotate the Pivot Arm until the Inking System Assembly “A” contacts the Print Drum “D”. There is a small amount of clearance in the mounting holes in the Pivot Arm. While holding the Inking System against the Print Drum, align the Inking System so that it points directly at the center of the Print Drum and tighten the two mounting screws securely.**

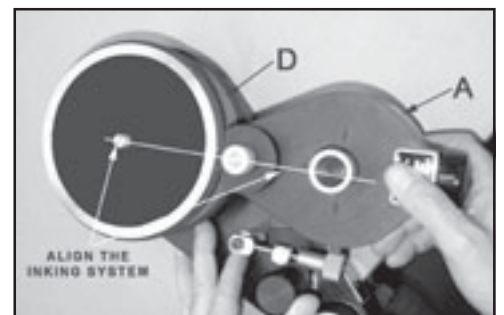

FIGURE 11

QUICK START

5 - Press the Inking System Assembly towards the Print Drum and adjust the Position Adjusting Screw “F” until the Knurled Drive Wheel “G” makes positive contact with the Friction Bearer “H” on the Print Drum. When the Pivot Arm Adjustment Knob “C” is tightened, the Knurled Drive Wheel should only contact the Friction Bearer Ring with enough pressure to drive positively when the print drum is rotated.

This adjustment procedure also controls the Transfer Roll contact with the printing dies. Excessive engagement pressure should be avoided as this will cause unnecessary drag on the print drum and result in smudged impressions.

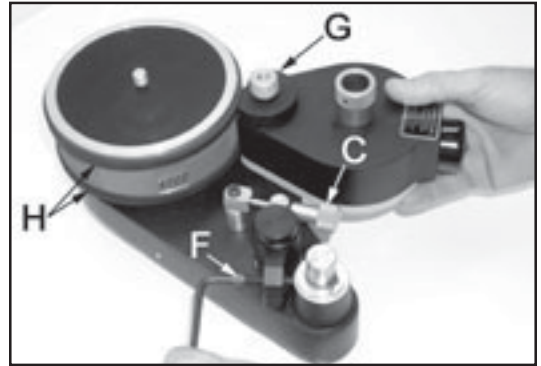

FIGURE 12

INSTALLING THE PRE-INKED ROLL

Warning: *Non-Porous inks contain flammable solvents. Do not smoke or handle these rolls in the presence of sparks or open flames. Inks will also stain clothing, furniture, carpeting and your hands. Rubber gloves should be worn during the following procedures.*

The ink roll you install on the coder must be properly pre-inked. If your coder was supplied with a dry XF Neoprene ink roll, refer to the Maintenance Section page 27 for inking instructions.

Rollers that have been pre-inked at the factory are normally slightly oversaturated with ink to compensate for potential solvent loss during shipping and storage. If you received a pre-inked ink roll with your coder, it is important to examine the roll prior to installation. **The ink roll should be thoroughly saturated with ink but not dripping wet.** Excess ink can be easily removed by lightly rolling the ink roll across a clean piece of absorbent paper.

1 - To install the pre-inked roll, first turn the Ink Roll Eccentric Adjusting Knob “I” to the “MIN” position.

This moves the ink roller axle away from the Transfer Roll and enables the ink roll to be installed without interference with the Transfer Roll during reassembly of the inking system.



FIGURE 13

2 - Loosen the Knurled Pivot Arm Knob “C” & swing the Inking System Assembly “A” away from Print Drum.

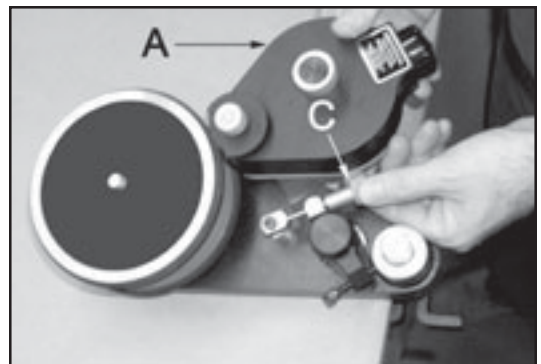

FIGURE 14

QUICK START

- 3 -While holding the Knurled Drive Wheel Cover “J” in place, remove the Knurled Cover Retaining Knob “K” by turning it counter-clockwise.

The Cover Retaining Knob holds the entire inking system together and other parts may fall free from the coder if not held securely when this knob is removed.

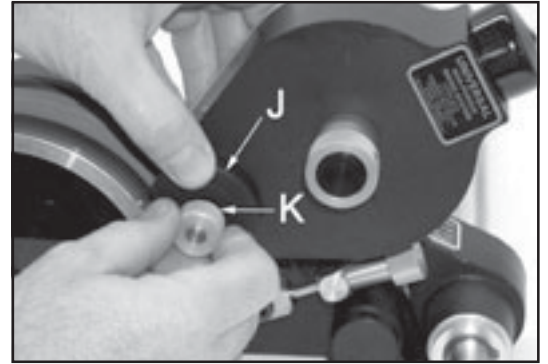

FIGURE 15

- 4 -Hold the Inking System Cover “L” in place and remove the Knurled Drive Wheel Cover “J”.

The Knurled Drive Wheel Cover is very loose fitting.

Note: The flat on the side of the Drive Wheel Cover is aligned towards the print drum. During reassembly, this must be replaced in the same position.

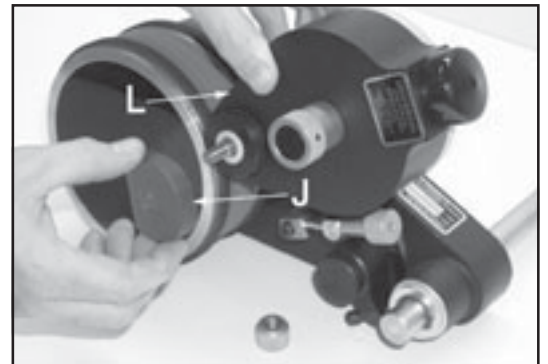

FIGURE 16

- 5 -Continue to hold the Inking System Cover and Remove the Knurled Drive Wheel “G”.

The Knurled Drive Wheel rests on top of the Transfer Roller and is installed over 3 stainless steel drive pins which protrude through 3 mating holes in the Drive Wheel.

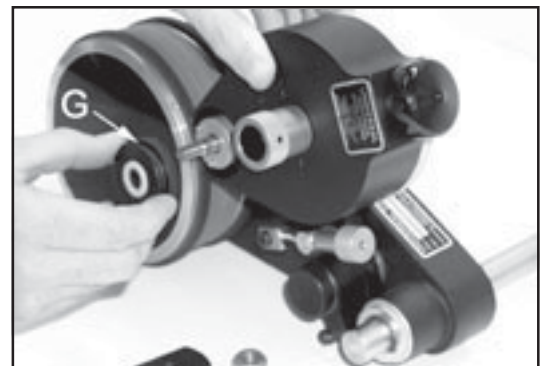

FIGURE 17

- 6 -Carefully pull the Inking System Cover “L” directly away from the Inking System Baseplate “M”. Do not let the cover drag across the surface of the Transfer Roller “N”.

The Transfer Roll Surface is a finely engraved Delrin plastic material which can be easily scratched. When assembled, the Transfer Roll resides in a very close fitting cavity in the Inking System Cover.

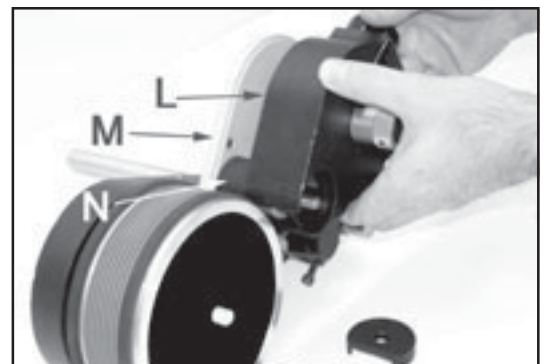

FIGURE 18

QUICK START

- 7 -Put on a pair of rubber gloves and remove the pre-inked ink roller from the storage container by inserting a small rod (a pencil works nicely) in the center of the core.**

Keeping ink off your gloves at this stage will prevent contamination of the external parts of the coder during roll installation.



FIGURE 19

- 8 -Inspect the roll for excess surface wetness. Remove any excess ink by rolling the roll lightly over a piece of absorbent paper.**

Rolls which have been pre-inked at the factory are typically over saturated with ink to compensate for potential solvent loss during shipping and storage. Installing an over saturated roll on the coder will result in ink leakage from the Inking System and in extreme cases may damage the ball bearings in the Transfer Roll. When the roller is installed, it must be thoroughly saturated with ink but you should not be able to see any liquid ink on the surface of the roll. If necessary, blot excess ink from the sides of the roll with a dry paper towel before installation.



FIGURE 20

- 9 -Install the ink roll on the Ink Roll Axle “O” by aligning the end of the rod or pencil with the end of the axle and pushing the roll onto the axle.**

When this step is complete, remove the rubber gloves to prevent ink contamination with the external parts of the coder.

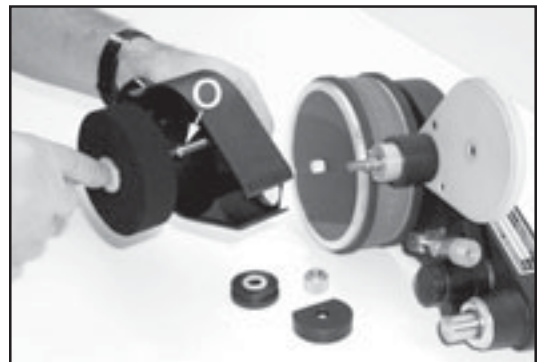

FIGURE 21

- 10 - Immediately replace the Inking System Cover “L” by carefully guiding the cover over the Transfer Roll “N”. Try not to let the cover contact the surface of the Transfer Roll to prevent scratching. Make sure the Cover is seated properly against Baseplate “M”.**

While handling the ink rolls, solvents will evaporate from the rolls very rapidly at normal room temperatures. The Inking System Cover must be replaced quickly to prevent solvent loss.

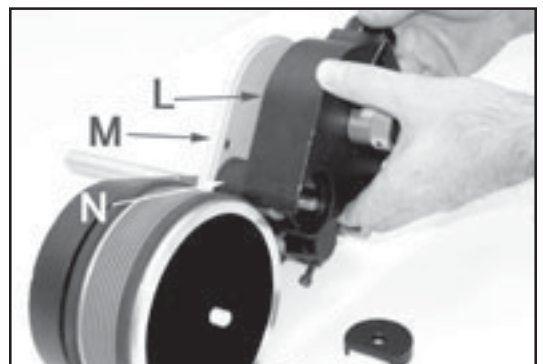

FIGURE 22

QUICK START

- 11 -Replace the Knurled Drive Wheel “G” by aligning the 3 small holes with the 3 stainless drive pins on the top of the Transfer Roll “N” and pressing the Drive Wheel onto the Transfer Roll.**

The tops of the stainless pins will be flush with the top of the Drive Wheel when seated properly.



FIGURE 23

- 12 -Replace the Knurled Drive Wheel Cover “J” and rotate it into position with the flat edge directly facing the Print Drum.**

Hold the Drive Wheel Cover and Inking System Cover in place.



FIGURE 24

- 13 - Replace the Knurled Cover Retaining Knob “K” and lightly tighten. Do not over tighten this knob or you may bend the top of the Knurled Drive Wheel Cover “J” and cause it to bind against the Knurled Drive Wheel. Now retighten the Pivot Arm Knurled Knob.**

The Cover Retaining Knob should be just tight enough to keep the Inking System Assembly together and prevent the Drive Wheel Cover from rotating out of position.



FIGURE 25

QUICK START

INSTALLING THE PRINTING DIES

1 - Align the ribbed backing on the Printing Dies “P” with the mating drum covering on the Print Drum “D” and press firmly until they are completely engaged. It is best to install the dies as close to the middle of the print area on the Print Drum as possible.

Individual character codes or text messages are installed in a mirror image of normal written text. In other words install in a right to left direction as shown. When printed, codes or text installed in this orientation will print in normal left to right order.



FIGURE 26

Tip: To make die installation easier, moisten a sponge with water containing a small amount of liquid detergent. Lightly moisten the back of the printing die and then immediately press the die into the drum cover. Do not apply too much liquid or the dies will slip during printing.

Note: Do not apply silicone, oil or any other lubricating agent to the rib backing or the dies will not hold properly during printing.

2 - When using the smaller individual characters to make up a code message, use the Type Blocking Kit “Q” included with your coder to support the leading and trailing ends of the type as shown.

Characters with only a 2 or 3 rib backing do not have the stability of the larger sizes when snapped into the drum cover. Adding the rib backed type blocks on either side of the code will provide added stability. The Type Blocks are not as thick as the Type and will not pick up ink from the Transfer Roll.



FIGURE 27

QUICK START

ADJUSTING THE INK ROLL ECCENTRIC

1 - After the printing dies are installed on the print drum, manually rotate the print drum continuously in one direction while slowly rotating the Ink Roll Eccentric Adjusting Knob “I” from the “MIN” position towards the “MAX” position. Turn the Eccentric Knob in small increments and observe the face of the Printing Dies “P” for signs of ink between each adjustment.

As soon as you can see complete ink coverage on the die faces, stop rotating the eccentric. Proper adjustment will normally be reached when the reference line on the Eccentric is somewhere between the 2 and 3 dial position.



FIGURE 28

This adjustment procedure brings the Ink Roller into contact with the surface of the Transfer Roller which in turn applies the ink to the face of the printing dies. Do not rotate the Ink Roll Eccentric Knob further than necessary towards the “MAX” position or the excess contact pressure will squeeze ink out of the ink roll and may cause dripping inside the cover.

**FOR MOUNTING INSTRUCTIONS
REFER TO THE APPROPRIATE SECTION
FOR YOUR APPLICATION**

**WEB PRINTING - PAGE 19
CARTON PRINTING - PAGE 23**

BASIC PRINCIPLES OF OPERATION

NON-POROUS INKING SYSTEM

Inks designed for printing on non-porous surfaces contain very fast drying alcohol solvents, a component to impart color which can be either a liquid “dye” or a finely ground solid or “pigment”, and a resin material which binds the color medium to the material surface. When the printed marks are applied by the coder, the solvents rapidly evaporate from the surface of the material leaving only the dried resin and color.

Preventing rapid solvent loss from the inking system, which would cause the coder to stop printing, has traditionally been a very difficult task. Universal’s patented Non-Porous Inking System design has overcome this problem by enclosing all of the inking system components in a tightly sealed housing. This unique design offers the capabilities of a flexographic printer without the limitations associated with having an open well of ink. The advantages of this design include minimal maintenance requirements, unrestricted mounting configurations and the ability to rapidly change ink colors.

The inking system is comprised of two main components as shown in Figure 29. The ink roll serves as a reservoir for the ink, and a transfer or “anilox” roll transfers the ink from the ink roll to the face of the printing dies. To prevent the loss of ink solvent through evaporation, these rolls are mounted in separate precision machined cavities in a sealed aluminum housing. The integrity of the housing is such that the system can be left idle for days without risk of the ink roll drying out.

The ink roll is installed on an eccentric mounted axle which enables the roll to be adjusted into contact with the transfer roll. The surface of the transfer or “anilox” roll is finely engraved with thousands of microscopic cavities which picks up ink from the ink roll and transfers it to the surface of the printing dies. Since the transfer roll applies a very thin film of ink to the die face, the printed marks dry very rapidly.

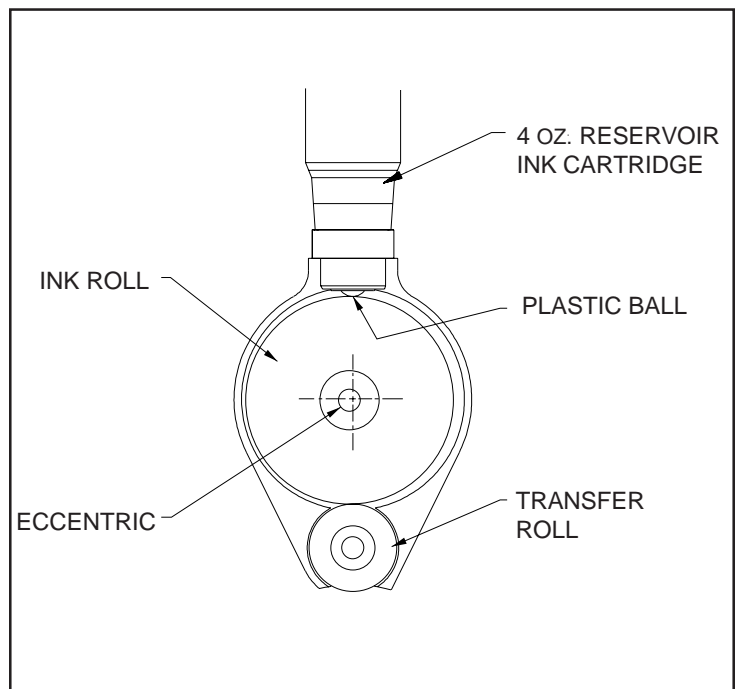

FIGURE 29

USING THE 4 OZ. RESERVOIR INK CARTRIDGES

It is important to note that the Reservoir Ink Cartridge shown in Figure 29 is not considered to be an integral part of the inking system but is used only to re-ink the ***XF neoprene ink roll*** when needed. ***The 4 Oz. Reservoir Ink Cartridges should be installed only after the ink supply in the XF neoprene ink roll has been depleted and the printed marks indicate a need for more ink.*** Depending on the amount and size of the text being printed and number of imprints being applied per hour, the ink capacity of the XF neoprene ink roll may last anywhere from 1 hour to several days of continuous operation. Installing a 4 ounce Reservoir Ink Cartridge prematurely may result in over saturation of the XF neoprene ink roll and flooding of the inking system. 4 Oz. Reservoirs Ink Cartridges are not compatible with ketone or petroleum based inks and cannot be refilled after use.

Note: The MT Ink Roll is disposable by design and is not to be used with the 4 oz. ink cartridge. When the ink is depleted from the MT Ink rolls they are to be discarded.

BASIC PRINCIPLES OF OPERATION

When a Reservoir Ink Cartridge is threaded into the bottle port, the plastic ball in the cartridge comes into contact with the surface of the neoprene ink roll. When the ink roll rotates during the printing operation, a thin film of ink is transferred from the reservoir cartridge onto the surface of the ink roll. The printed impressions will improve within a few seconds after installation of the cartridge. When the printing operation is stopped, the Reservoir Ink Cartridge automatically stops feeding ink to the roller to prevent over saturation during idle periods.

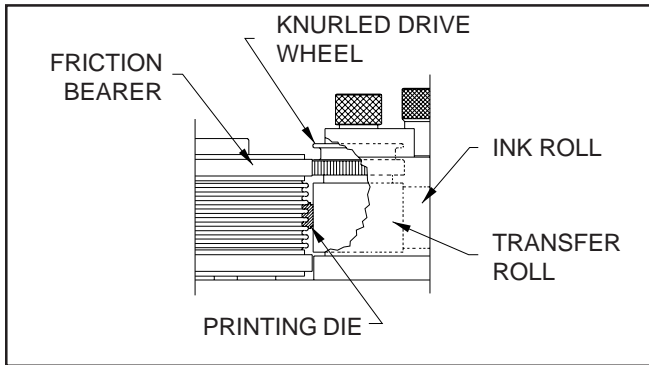

FIGURE 30

The knurled drive wheel shown in Figure 30 sits on top of the transfer roll and is engaged by three stainless steel drive pins. The knurled face of the drive wheel runs in contact with a friction bearer on the print drum. When the print drum starts to turn, the knurled drive wheel rotates the transfer roll at the exact surface speed of the die face. Keeping these two surfaces running at a synchronous speed ensures a uniform coating of ink on the die face and extends die life.

SELECTING AN APPROPRIATE INK

Universal's Non-Porous Inking System is compatible with a wide range of alcohol base marking inks. Although we offer a variety of inks for specific applications, you are not restricted to using only Universal brand inks. When selecting inks from other manufacturers however, it is your responsibility to make sure the inks are compatible with the coder.

Dye base inks contain liquid color which is translucent and will provide good color contrast only on light colored materials. These inks are generally faster drying than pigmented inks and normally produce less residue buildup on the transfer roll and printing dies, thus requiring less frequent cleaning of the coder. Although dye base inks are normally the easiest to use, they will fade more rapidly than pigmented inks when exposed to direct sunlight.

Pigmented inks contain finely ground solids which are opaque, providing much greater color contrast when marking on dark colored surfaces. These inks also resist fading when exposed to direct sunlight. Pigmented inks have a tendency to build up on the surface of the transfer roll and the die face more rapidly than dye base inks and will generally require more frequent cleaning of these parts.

The first step in selecting an appropriate ink, is to determine if the ink will bond to the surface of the material being printed and provide acceptable color contrast. It is normally recommended that inks be test printed on the material being marked with a rubber stamp to determine if the resulting marks are acceptable. Please note that when testing inks with a rubber stamp, the drying times will generally be much slower than when the inks are applied with the Non-Porous Conveyor Line Printer.

It is also extremely important to test the affect of other manufacturer's ink on the XF Neoprene ink roll. Since the ink roll must fit into a precision machined cavity in the inking system housing with little clearance, swelling of the roll, in reaction to non-compatible solvents in the ink, could cause serious problems with the performance of your coder. The dry XF neoprene ink roll measures 3.425" (86.99 mm) OD. After thoroughly saturating the ink roll with ink, the roll should not exceed 3.500" (88.90 mm) OD.

BASIC PRINCIPLES OF OPERATION

INK DRYING TIME CONSIDERATIONS

Depending on the specific characteristics of the printing application, some consideration needs to be given to the drying time of the ink and its suitability for the application. Printing on a plastic film in an intermittent motion Form and Fill Machine may require a slower drying ink formulation than that recommended for high speed continuous web printing applications. Although extremely fast drying inks are normally specified by customers in all applications, the ink must be suitable for the specific application or it will not perform properly in the coder.

Universal #100 ink is an extremely fast drying formulation and is normally recommended for continuous motion web printing applications. In these applications, the ink must dry very rapidly on the material to prevent downstream transfer to idler rolls. When the print drum is rotating at high speeds, the dies rotate past the Transfer Roll where ink is applied and within milliseconds the die face contacts the surface of the material being printed and the impression is transferred. (See Figure 31)

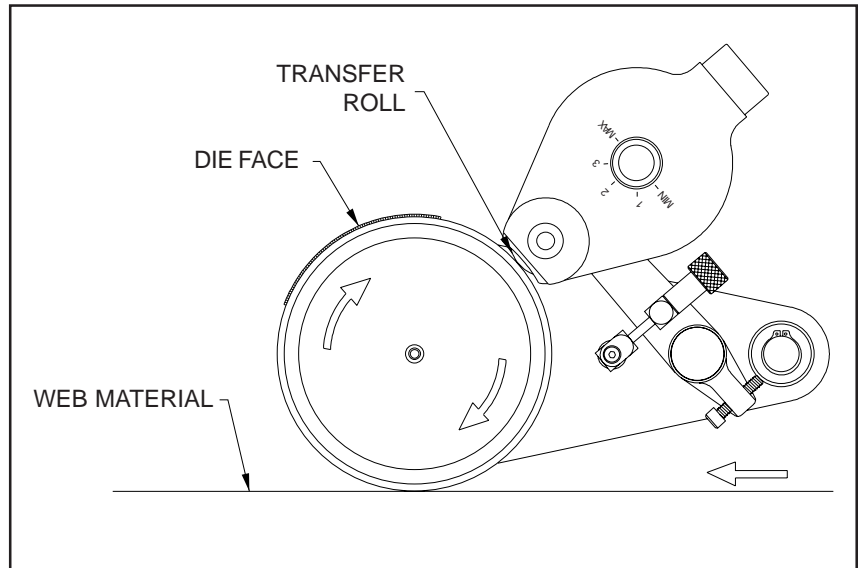

FIGURE 31

When printing on very slow moving web materials, the print drum rotates at much slower speeds. As a result, when the dies rotate past the Transfer Roll and the ink is applied, it may take several seconds for the dies to contact the web. Since the solvents in the #100 Inks evaporate very rapidly at normal room temperatures (even from the die faces), the die faces may be dry before contact with the web material. In these applications, a slightly slower drying ink formulation would be necessary to ensure that the ink remains wet on the die faces until they contact the web material.

When the coder is installed on a Form and Fill machine, the plastic film may move at fairly high speed when pulled from the supply roll but it stops for a period of time during the product fill cycle. In these applications, if the die face has already rotated past the Transfer Roll and picked up ink and the web motion stops for several seconds, a very fast drying ink like the #100 will flash off the die face before the web motion resumes. It is therefore necessary to take into consideration the cycle rate of the particular machine when selecting an ink.

WEB PRINTING

This section applies to the installation of the Non-Porous Conveyor Line Printers for printing on continuous web materials such as plastic films, rubber sheeting, metals and other extruded materials.

Careful consideration should be given to selecting an appropriate area in the production line for installation of the coder. Since the coders are friction driven by the moving web of material, a primary factor is to select an area where the position of the web material is accurately controlled and preferably supported by an idler or guide roller on the underneath side as shown in Figure 32.

The only real consideration with respect to the attitude of the coder frame is that the 4 oz. reservoir ink cartridge (when installed) should be kept as near to a vertical position as possible with the plastic ball pointing down. This will ensure proper ink feed from the 4 oz. cartridge to the ink roll. When disposable Type MT Ink Rolls are used on the coder, 4 oz. Reservoir Ink Cartridges are not used and therefore the coder can be mounted in any convenient attitude. When installing the coder, the print drum axle of the coder should be in parallel alignment with the idler roll and the print drum should contact the web at the point where the web is tangent to the idler roll and solidly supported. It is also important that the distance "C" between idler roller "A" and idler roller "B" should be adequate so that at the maximum web speed, the ink will dry before the printed marks contact idler roller "B". If distance "C" is not adequate for the drying time of the ink used, a ghost image transfer of the marks may be overprinted on the web by idler roller "B".

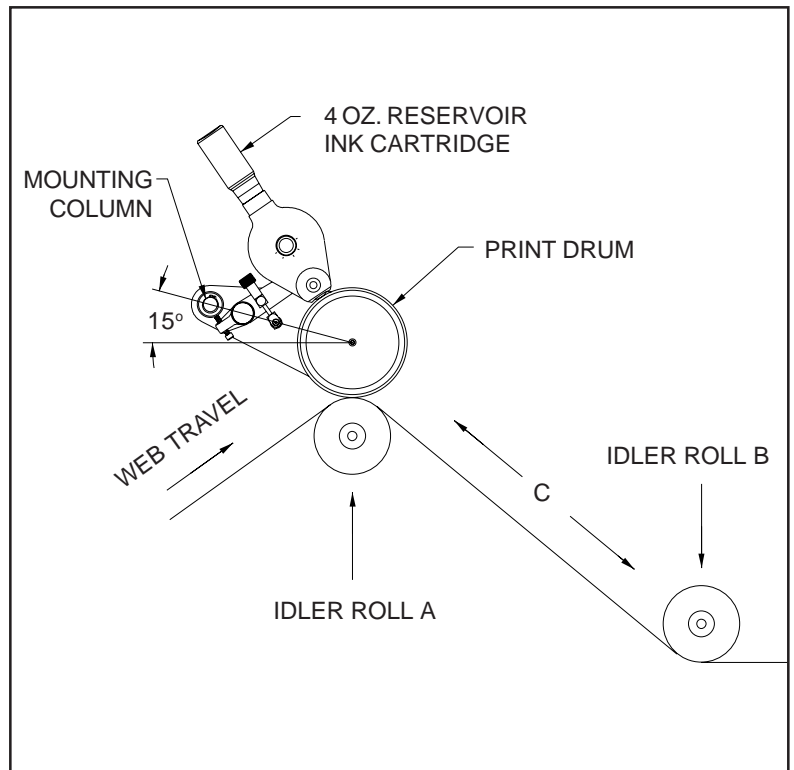

FIGURE 32

To eliminate this problem, if idler roller positions are not adjustable, a slight undercut in the face of idler roller "B" where the printed marks pass under the roll, will prevent the wet marks from touching the face of the idler. Generally the undercut in the idler roller needs to be only .020" - .030" deep and slightly wider than the printed marks as shown in Figure 33.

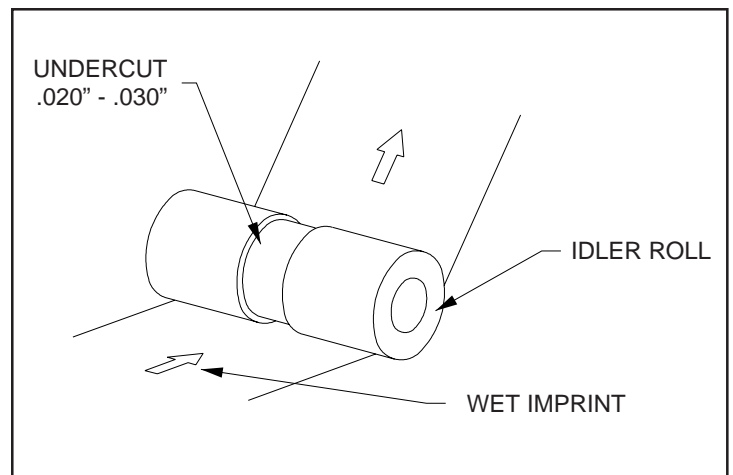

FIGURE 33

WEB PRINTING

In high speed web applications, the distance the web travels at a given speed in 2-3 seconds can be substantial. It is important to note that when the printed web is tightly rewound, the additional pressure applied to the printed marks can increase the possibility of a ghost image transfer of the ink to the back of the web.

If this situation occurs and the web speed cannot be slowed down to allow more drying time, air blowers can be used to direct heated air on the printed marks to accelerate drying. Preheating the web material slightly with hot air before printing can also be an effective method to decrease the drying time. If either of these techniques are used, it is recommended that the hot air blowers be electrically tied into the web feed motor energizing circuit. This will ensure that the blowers are turned off automatically if the web is stopped.

MOUNTING THE CODER

1 - After determining the best location to mount the coder, install the supplied mounting bracket (Figure 34) on a rigid surface using two 3/8" diameter bolts, nuts, washers and lock washers (not supplied). Be sure that the mounting column of the coder is parallel to the idler roll.

2 - Insert the mounting column into the mounting bracket and allow the print drum to pivot into contact with the idler roll. Do *not* tighten the bracket clamping screw at this time.

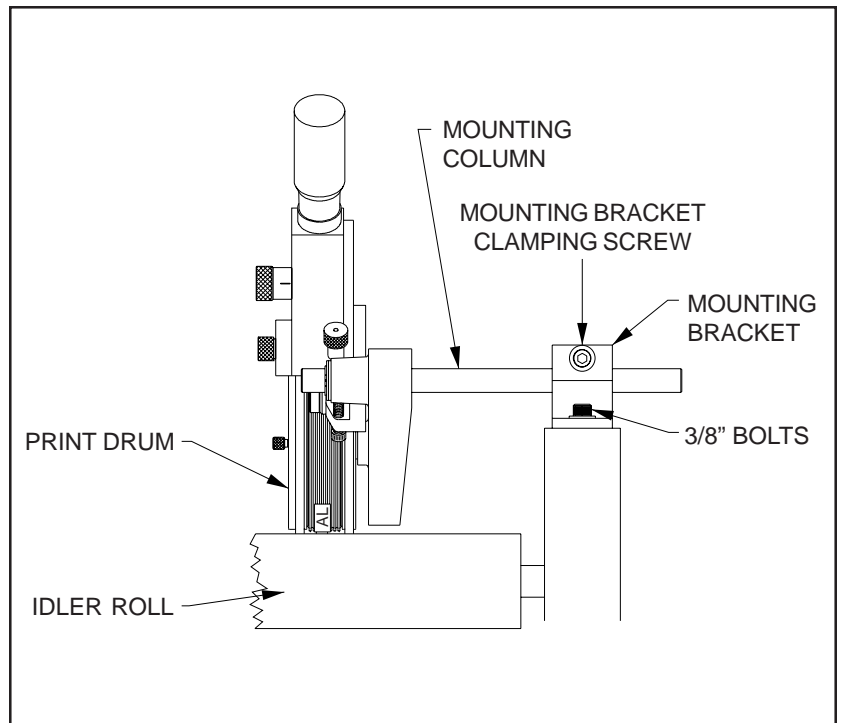

FIGURE 34

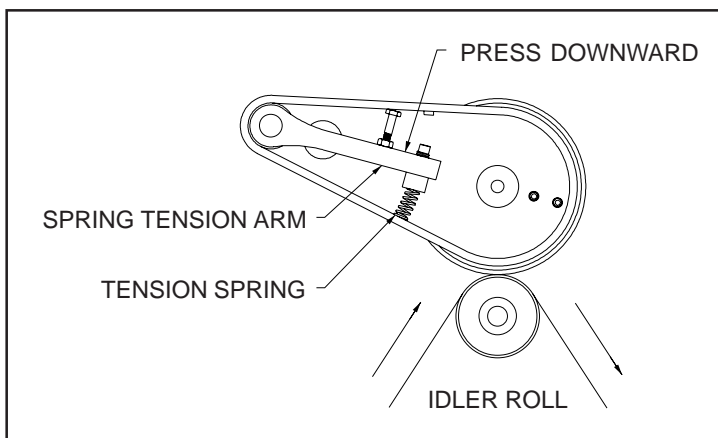

FIGURE 35

3 - Press down lightly on the spring tension arm to compress the tension spring slightly. (Figure 35) While holding a light pressure on the arm, tighten the mounting bracket clamping screw.

This procedure is used to adjust the contact pressure which the print drum exerts against the web. Only enough pressure should be applied to ensure positive friction drive of the print drum. Excessive contact pressure will impose unnecessary drag on the web and may result in poor print quality.

WEB PRINTING

DO NOT INSTALL A 4 oz. RESERVOIR INK CARTRIDGE AT THIS TIME. The coder is designed to print using the ink contained in the pre-inked ink roll. Since a freshly saturated Ink Roll was just installed on the coder, the system will have plenty of ink. Installing a 4 oz. Reservoir Ink Cartridge immediately will result in over saturation of the ink roll and flooding of the Inking System. The 4 oz. Reservoir Ink Cartridge should not be installed until most of the ink is consumed from the ink roll and the print quality shows signs that more ink is needed.

SPECIAL WEB PRINTING APPLICATIONS

In applications where the web material is too narrow for both friction drive bearers to contact the surface of the web, contact with one friction bearer is acceptable. When the web is too narrow for even one friction bearer to contact the web and still position the print as necessary, a custom made guide roller can often be utilized.

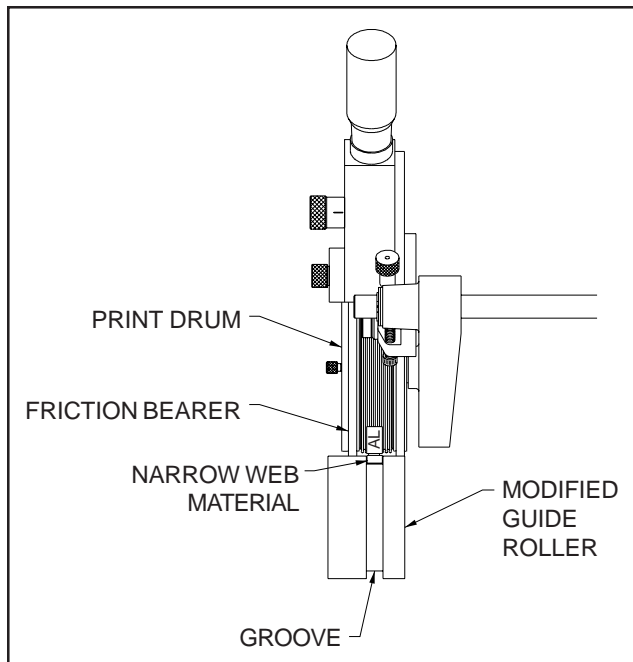

FIGURE 36

PRINTING ON NARROW WEB MATERIALS

Using this approach, the guide roll must be machined with a groove which will not only accurately guide the web material and drive the guide roll but it must also keep the surface of the web material flush with the surface of the guide roll where the friction bearers make contact. (See Figure 36.)

This method of mounting is generally more appropriate when the web material is extruded rubber or some similar material which has a high coefficient of friction since it must drive both the guide roll and the print drum. Using a custom guide roller which is driven by an external power source is certainly acceptable but it is generally rather costly since the surface speed of the guide roller must precisely match the speed of the web or smeared prints will result.

PRINTING DIRECTLY ON MASTER ROLLS

Universal Non-Porous Conveyor Line Printers can also be mounted on custom designed extension arms which will enable them to print directly on the surface of a master roll of web material as it is unwound. This technique is frequently used when conveniently positioned idler rolls are not available. In these applications, as the master roll of web material decreases in size, the mounting arm pivots and keeps the print drum in constant contact with the surface of the roll as shown in Figure 37. In these installations, the weight of the coder is used to supply printing pressure and typically the standard spring tension mechanism and mounting column are removed. Custom mounting brackets and extension arms should be carefully designed to keep the coder in an acceptable attitude when printing on a full roll of film all the way down to the smaller diameter of the core. For more details on custom mounting systems, contact our engineering department.

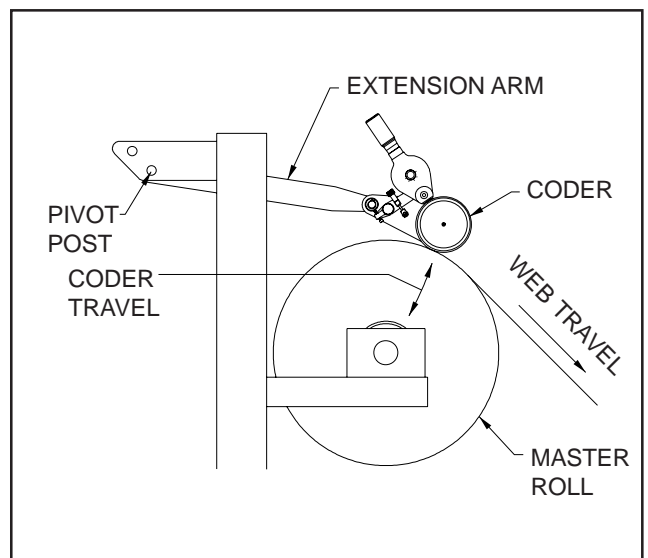

FIGURE 37

WEB PRINTING

GANG MOUNTING

In web printing applications where multiple coders are required to be mounted across the web, Universal offers special mounting hardware which facilitates gang mounting the coders as indicated in Figure 38. In these installations, special CLP-SBA Saddle Mount Bracket Assemblies are used in conjunction with an extruded structural aluminum mounting bridge. The 1.5" x 3.0" extruded aluminum bridge is ordered in an appropriate length to span across the web line and custom mounting plates are designed to support the bridge. The coders are installed using the Saddle Mounts which provide quick lateral positioning adjustment capabilities for the coder. To position the coder, a ratchet handle is loosened and the Saddle Mount can be moved laterally to the desired position and retightened.

For additional information on this mounting option, please contact our Engineering Department.

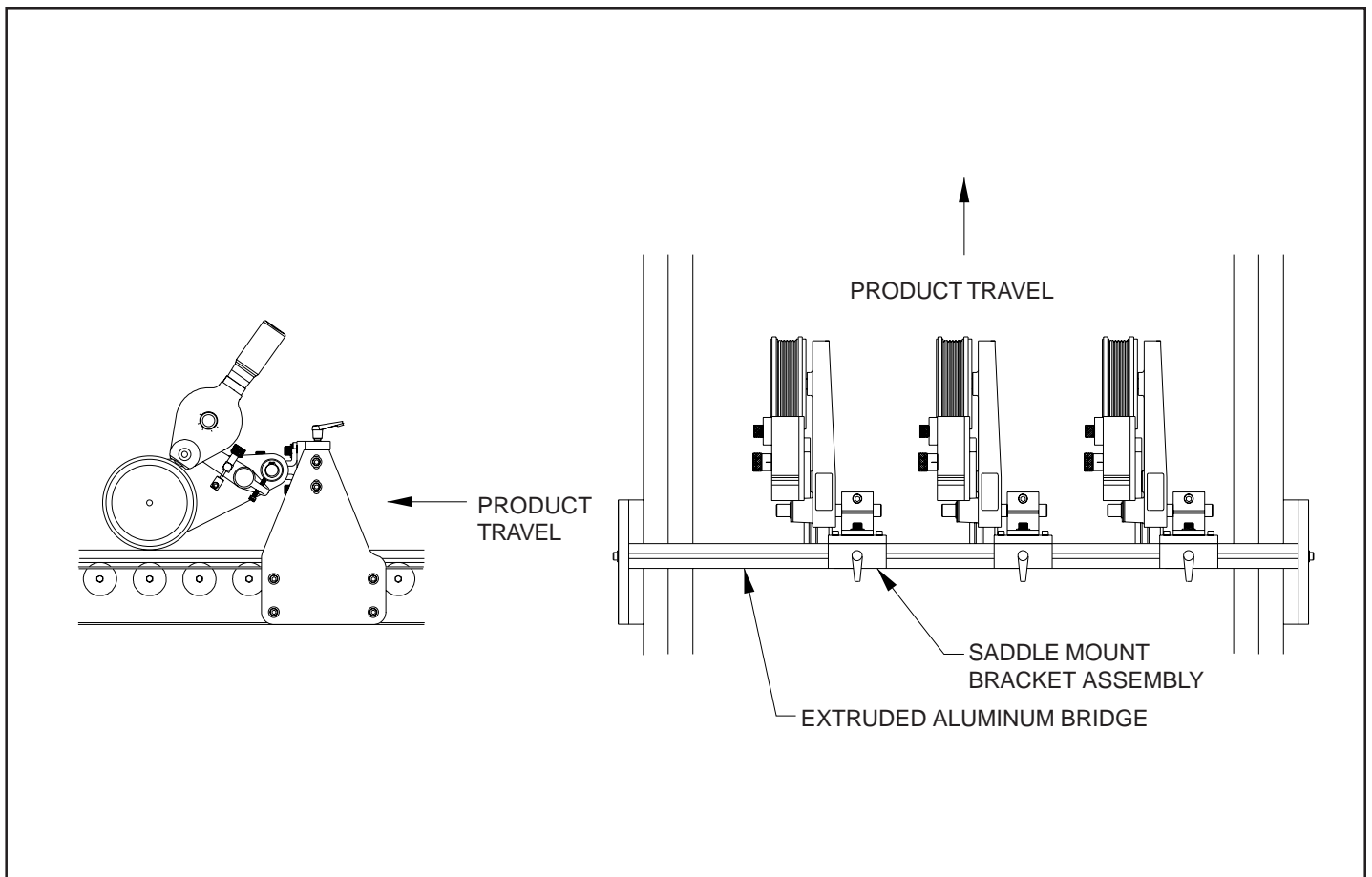

FIGURE 38

CARTON PRINTING

Printing on non-porous surfaces, such as waxed or varnished cartons, can be accomplished easily with Universal Non-Porous Conveyor Line Printers. The selection of an appropriate place for installation on your conveyor line or other packaging equipment is a very important consideration in the performance of your coder. The most important factor to consider is carton alignment.

CARTON ALIGNMENT

To ensure print reliability and prevent damage to your coders, the cartons must be accurately guided through the printing station by guide rails as shown in Figure 39. If your conveyor is not equipped with guide rails - they must be installed before proceeding with coder installation. Proper alignment of the cartons as they pass the printing station is imperative. Improper alignment will produce poor print quality, poor print registration, and in extreme cases, could damage the machine.

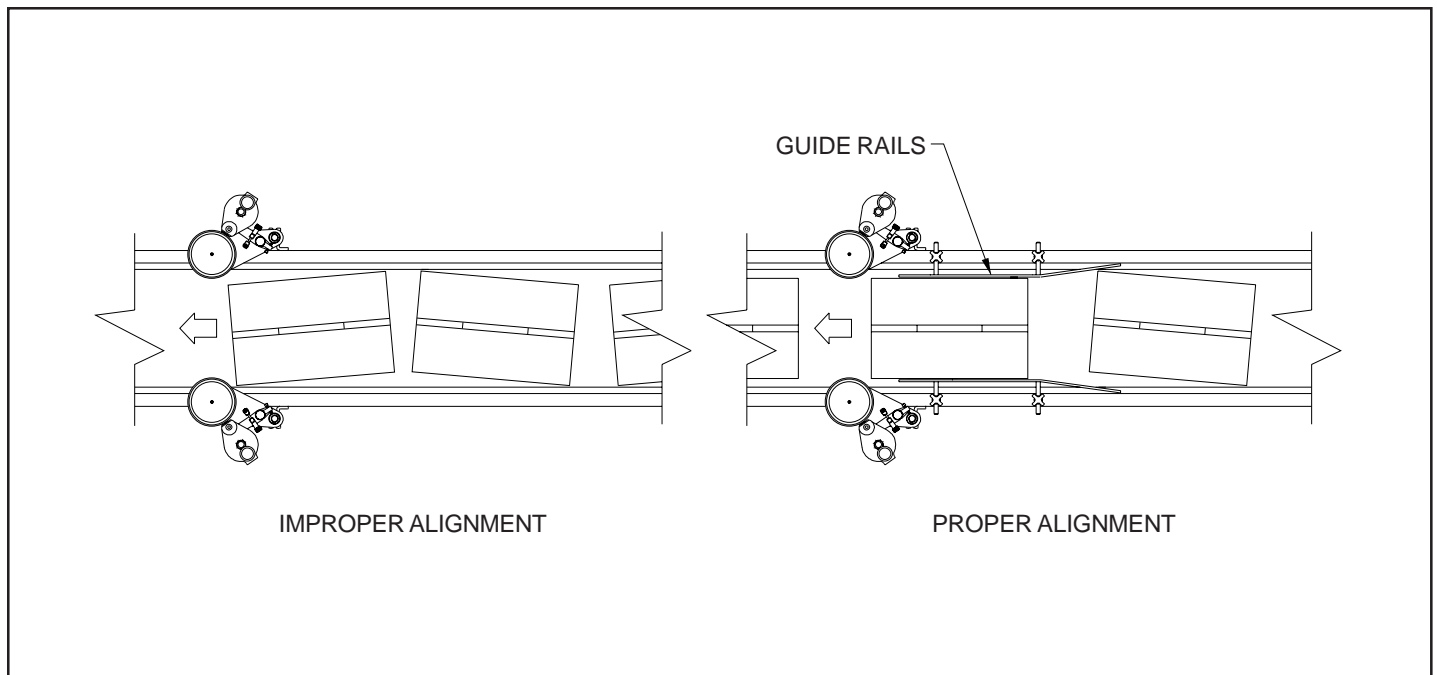

FIGURE 39

Universal Non-Porous Conveyor Line Printers are spring loaded so that the print drums will press against the carton surface on contact. This pressure is necessary to accomplish the friction drive rotation of the print drum and ensure enough printing pressure to give you a sharp impression. The spring tension mechanism on the coder will also compensate for slight variations in the width of the cartons without jamming the conveyor line. Excessive pressure, caused by improperly guided cartons, will result in smudged impressions and could cause damage to the spring tension mechanism.

CARTON PRINTING

Universal Non-Porous Conveyor Line Printers are designed so the frame of the machine will pivot on the mounting column. This allows the print drum to deflect, or swing, on contact with the leading edge of the carton a maximum of 2". It is recommended that cartons be aligned between guide rails with no more than 1/4" clearance on each side as shown in Figure 40. This should allow ample clearance for cartons and protect your printer from damage.

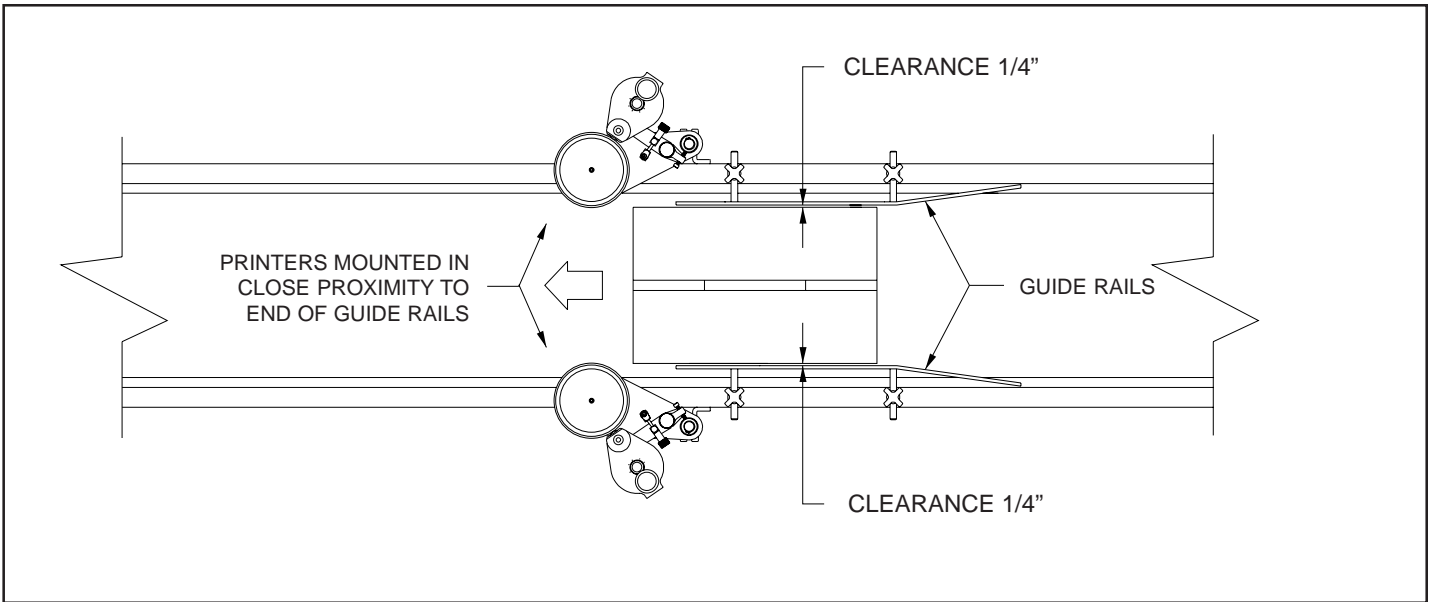

FIGURE 40

In most applications, installation of the printer can be accomplished by attaching the mounting bracket to the side rails of the powered conveyor using two 3/8" machine bolts. The printers should be mounted as close as possible to the end of the guide rails to ensure that proper carton alignment is maintained at the printing station.

Before tightening the mounting bolts, check alignment of the print drum. It is very important for proper tracking that the top of the print drum is parallel to the top of the conveyor (Figure 41) and the side of the print drum is parallel to the side of the carton (Figure 42). Once this alignment has been achieved, tighten the mounting bolts.

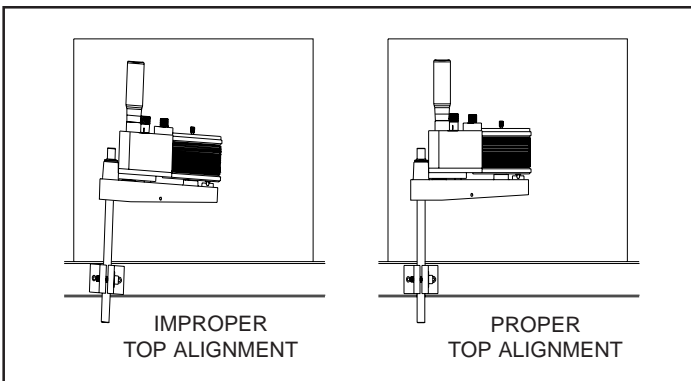

FIGURE 41

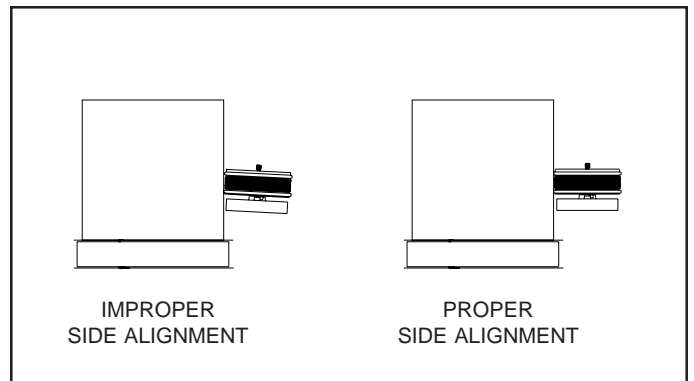

FIGURE 42

CARTON PRINTING

Loosen the mounting column clamping bolt (Figure 43) and position the printer to the required height for printing. Swing the printer into position so that the print drum will lightly contact the side of the cartons as they emerge from between the guide rails. Check the print drum contact with the cartons while the conveyor is under power and adjust the print drum position to obtain approximately 1/4" - 3/8" deflection (Figure 44).

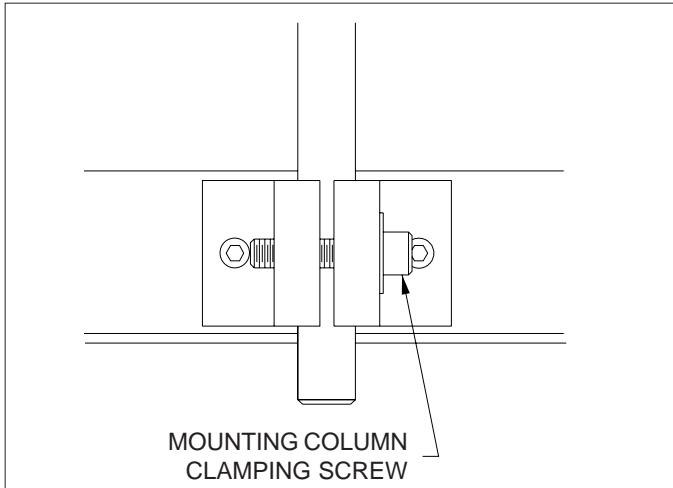

FIGURE 43

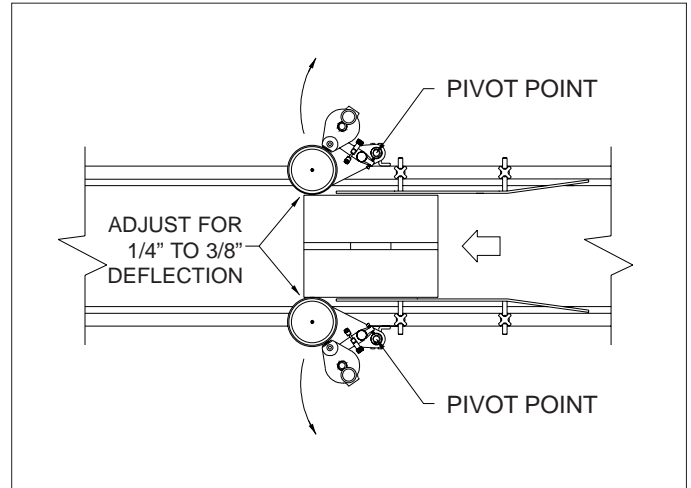

FIGURE 44

DIE POSITIONING FOR INDEXING APPLICATIONS

Non-Indexing models of the coder do not offer print registration capabilities, therefore mounting the printing dies at a specific location on the print drum is not important. On Indexing machines, however, the position of the die on the print drum determines the registration of the print on the carton. Since non-porous marking inks are normally extremely fast drying, die positioning will also have an affect on the ability of the coder to reliably transfer ink to the carton surface. Production cycle rates, ambient temperature and ink selection are also factors which have to be considered to ensure proper performance of the system.

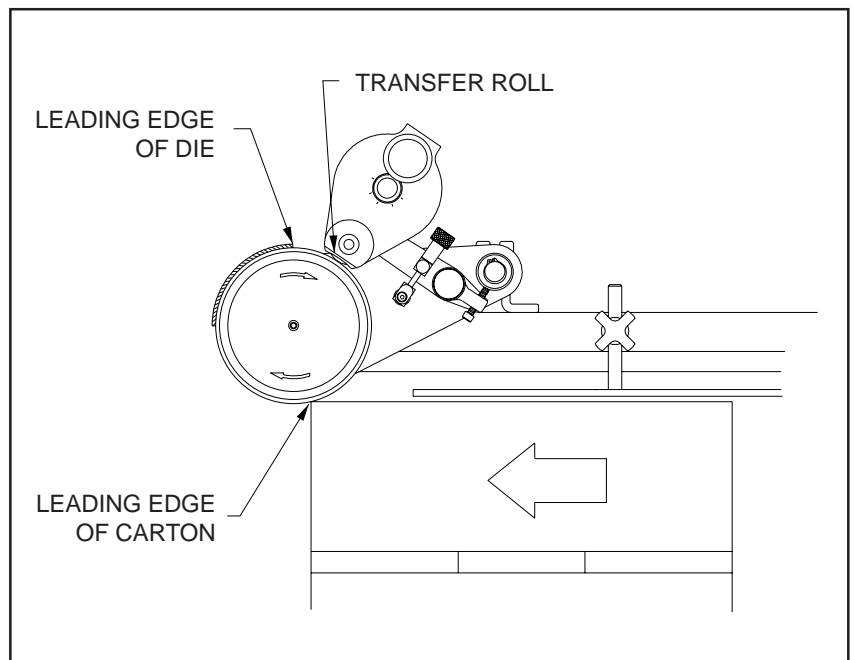

FIGURE 45

Figure 45 illustrates the best die position for carton printing when using extremely fast drying inks. Note that the leading edge of the printing die should be positioned rotationally upstream of the transfer roll. When the leading edge of the carton contacts the print drum, the drum begins to rotate in a clockwise direction. The die travels a short distance and then contacts the transfer roll where ink is applied to the die face. When the die contacts the carton the mark is applied. The print drum will continue to rotate until the trailing edge of the carton passes the coder, then the print drum will automatically return to the same starting position.

CARTON PRINTING

Although installing the printing dies in this position restricts how close to the leading edge of the carton you can register the print, it is one of the only ways to ensure a good imprint on every carton. Since the fastest drying non-porous inks will dry in approximately 2 seconds at 75 Degree F. ambient temperature, the ink will also dry on the die face within 2 seconds after it is applied by the transfer roll. If the dies have not contacted the carton surface before then, no imprint will be transferred to the carton.

If the cycle rate of the production line is very fast and the ambient temperature is relatively low, the printing dies could be positioned rotationally downstream of the transfer roll so they print much closer to the leading edge of the carton. When the coder completes one printing cycle, a portion of the die or all of the die may have already passed the transfer roll and picked up ink in preparation for printing the next carton. The machine can remain idle like this for only a second or so before the next carton must contact the print drum or the ink will dry on the die face and not be transferred to the carton.

If your production cycle rate is not fast enough but you still need to print close to the leading edge of the carton, the only alternative is to use a slower drying non-porous ink. When making the ink selection, be sure to consider ambient temperature, it can have a dramatic affect on ink drying times. Hot temperatures make inks dry faster, cold temperatures retard drying.

MAINTENANCE

PRE-INKING A NEW INK ROLL

When you are ready to begin printing, you must first install an ink roll which has been properly pre-inked with the appropriate non-porous ink. Unless you ordered a pre-inked roll with your machine, you will find a dry roll in a plastic container with your coder.

Note: *Dry rolls cannot be inked automatically using the 4 Oz. Reservoir Ink Cartridges.*

Warning: *Non-Porous Inks contain flammable solvents. Do not smoke or handle these rolls in the presence of sparks or open flames. Inks will also stain clothing, furniture, carpeting and your hands. Rubber gloves should be worn during the following procedures.*

A dry XF Neoprene ink roll has the same characteristics as a sponge with the capacity to absorb approximately 3-4 fluid ounces of ink in 1" rolls and 6-7 fluid ounces of ink in 2" rolls. Please follow the guidelines below to properly pre-ink your roll:

- 1 - Remove the dry roll from the storage container. Pour 3 to 4 oz. of ink into the container. **Note:** The ink level should be just below the textured line "R" on the side of the container.



FIGURE 46

- 2 - Carefully place the roll into the container of ink. Using your finger tips, firmly press down on the foam side of the ink roll and then release the pressure. Repeat this process several times while rotating the roll in the container and pressing on different areas. This will force the air out of the roll and the voids will be filled with ink.



FIGURE 47

Remove the roll from the storage container and turn it over, placing the un-inked side down in the container. Repeat the process above until all the ink in the container has been absorbed into the roll.

- 3 - Inspect the roll to ensure it is completely saturated with ink but not dripping wet. If the surface of the roll seems excessively wet after inking, remove the excess ink by inserting a rod through the core and while pressing down lightly, roll the roller across a clean piece of paper.



FIGURE 48

After this process is completed, the roll should immediately be installed on the coder or it should be placed back in the storage container and the lid tightly sealed to prevent solvent evaporation.

MAINTENANCE

CLEANING THE TRANSFER ROLL

The surface of the transfer roll is made from DuPont Delrin material and the O.D. of the roll is finely engraved which enables it to hold a uniform film of ink. This surface material is very fragile and under no circumstances should you attempt to clean it with anything abrasive.

Warning: *Most of the ink solvents used for cleaning are flammable liquids. Follow all safety precautions recommended by the manufacturer during this process.*

1 - To clean dust and ink residue from the surface of the transfer roll, first remove it from the coder. Lightly saturate a soft cotton cloth with the appropriate ink solvent and gently rub the surface of the roll until it is clean.

DO NOT SUBMERGE THE TRANSFER ROLL IN SOLVENT!

If the transfer roll is submerged in solvent, the bearings will be permanently damaged.



FIGURE 49

CLEANING THE CODER

1 - Periodically, the inking system should be disassembled and inspected for ink residue and dust contamination. To remove ink contamination from the surface of the machine, moisten a soft cotton cloth with the appropriate ink solvent and rub it across the contaminated area.

The frequency of required cleaning can be greatly reduced if the inking system is kept in proper adjustment during normal operation and if the ink roll does not become over saturated with ink.



FIGURE 50

MAINTENANCE

CLEANING THE PRINTING DIES

All inks which are formulated for printing on non-porous surfaces contain a resin binder which bonds the dye or pigment in the ink to the surface of the material being printed. As the ink begins to dry, this binder becomes “tacky” or “sticky”. While in this stage of the drying process, the tack on the dies will tend to pick up both airborne dust and any dust or dirt on the surface of the material being printed. When this happens, the dies should be cleaned or replaced. The easiest method of cleaning the dies requires the appropriate solvent for the ink being used, a pair of rubber gloves, safety glasses, an apron to protect your clothing is recommended, a toothbrush, some clean paper towels and a plastic bag to protect your workbench from staining. (Naturally, the toothbrush will never be suitable for oral hygiene use after this process.)

After some period of use, the accumulation of contaminants on the dies will cause degradation of the print quality; cleaning the printing dies, excluding excessive wear to the die face, will restore the print quality of the coder.

- 1 - Place the contaminated Printing Die on top of several layers of paper towels to absorb the excess solvent. Pour just enough solvent on the face of the die to cover the die face.**

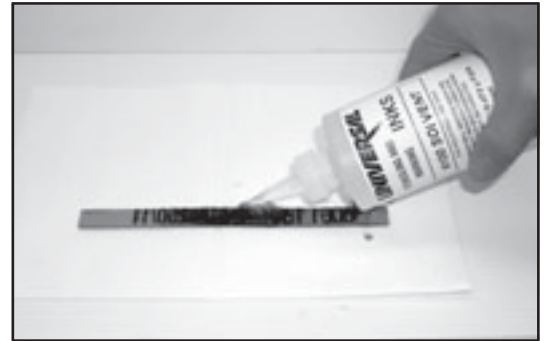

FIGURE 51

- 2 - Using the toothbrush, carefully scrub the face of the die to remove the contamination and old ink as shown in. Add more solvent as necessary and repeat the process until the die is clean.**

Do not submerge or soak the dies in solvent as this may cause swelling of the rubber compound.



FIGURE 52

- 3 - Blot the surface of the die with a clean paper towel to dry as shown in and reinstall the clean dies on the coder.**



FIGURE 53

MAINTENANCE

MOUNTING CONFIGURATION CONVERSION

LEFTHAND / RIGHTHAND FIELD CONVERSION

Mounting configuration conversion involves the “mirror image” reversal of the pivot arm assembly that holds the inking system and the tension arm assembly which provides the printing pressure. Indexing printers require the additional reversal of the index ramp and repositioning of the index ring.

Universal Non-Porous CLP Coders are assembled at the factory for either right-hand or left-hand mounting. If field conversion is required, the following steps will guide you through the conversion process.

PIVOT ARM & INKING SYSTEM ASSEMBLY CONVERSION

- 1- Loosen the Pivot Arm Adjustment Knob and rotate the Inking System away from the Print Drum slightly.
- 2- Remove the Inking System Assembly from the coder by removing the 2 socket head cap screws on the underneath side of the Pivot Arm.
- 3- Remove the Pivot Screw and lift the tension adjustment assembly off of the coder.
- 4- Remove the Pivot Arm Cap and lift the Pivot Arm assembly off its axle.
- 5- Reinstall the Pivot Arm on the axle in the opposite or “mirrored” orientation and replace the Pivot Arm Cap.
- 6- Remove the Position Adjusting Screw and reinstall in the reverse position.
- 7- Replace the tension adjusting assembly and the Pivot Screw.

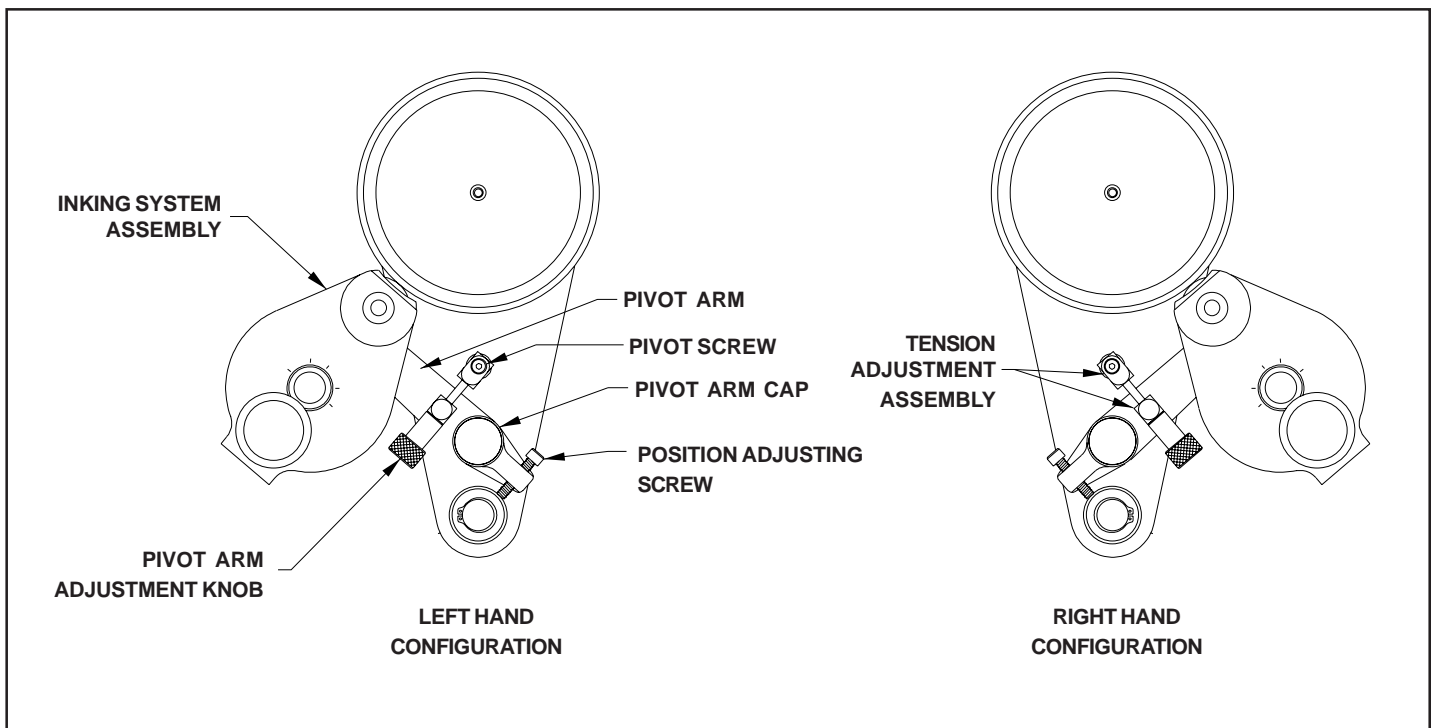

FIGURE 54

- 8 - Remove the Baseplate Plug from the bottom side of the Inking System Assembly Baseplate (See Figure 55).
- 9 - Reinstall the Baseplate Plug in the threaded hole on the opposite side of the Baseplate. Thread the Plug into the Baseplate only until the flush with the Baseplate surface.

MAINTENANCE

10 -Reinstall the Inking System Assembly and adjust as explained on Page 9 - Installing the Inking System Assembly.

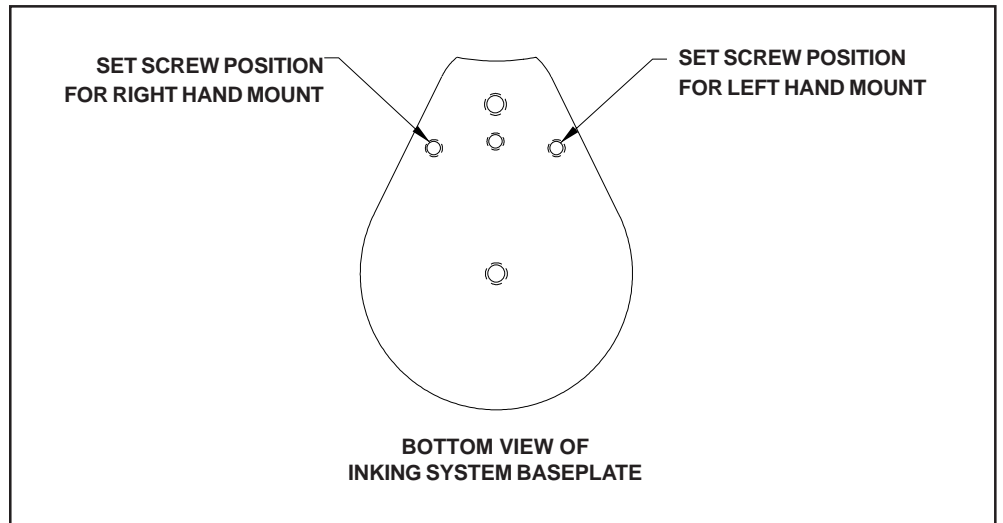

FIGURE 55

TENSION ARM ASSEMBLY CONVERSION

- 1- Loosen the Lock Nut and screw the Adjusting Bolt in to relieve the spring pressure (Figure 56).
- 2- Remove the spring by lifting the end off the Locating Button.
- 3- Remove the Adjusting Bolt and replace it on the opposite side of the Tension Arm.
- 4- Remove the Spring Cup and replace it on the opposite side of the Tension Arm.
- 5- Replace the Spring by inserting one end into the Spring Cup and lifting the other end over the Locating Button.
- 6- Readjust the position of the Adjusting Bolt to center the Tension Arm between the sides of the coder base plate. Snug the Lock Nut against the Tension Arm to prevent movement from conveyor vibration.

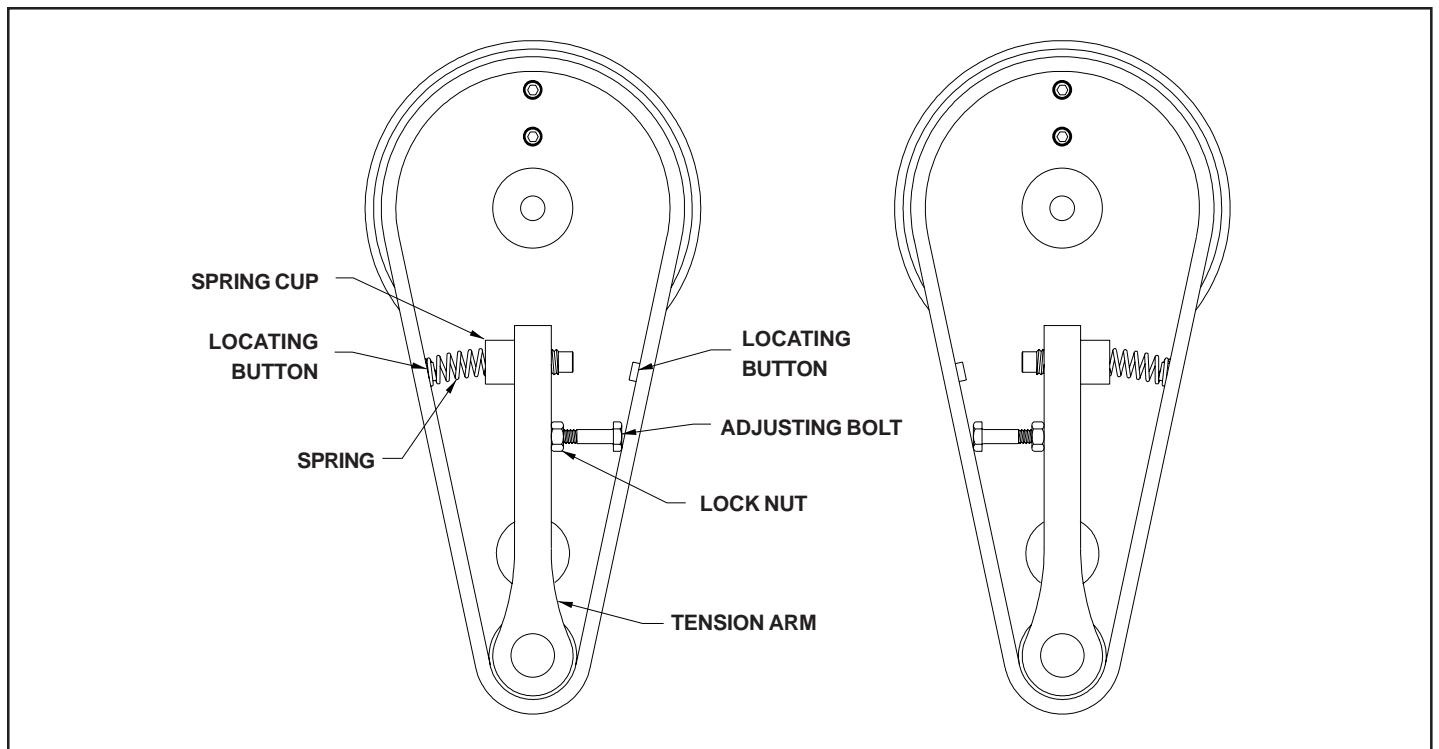

FIGURE 56

MAINTENANCE

PRINT DRUM INDEX MECHANISM CONVERSION

- 1- Using a 5/64" hex wrench, loosen the Nylon Tip Set Screw located in the top rim of the Print Drum.



FIGURE 57

- 2- Remove the Print Drum Dust Cover.



FIGURE 58

- 3- To relieve the spring tension on the index mechanism, rotate the Print Drum approximately 3/4 turn. The Index Compression Springs will now be in the fully extended (relaxed) position.



FIGURE 59

- 4- Using a 5/32" hex wrench, remove the two Index Ramp Mounting Screws which are located on the under side of the Coder Baseplate. The Index Ramp will be reinstalled in the opposite orientation to allow the Print Drum to turn in the reverse direction.



FIGURE 60

MAINTENANCE

- 5- Using a 1/8" hex wrench, loosen the Brass Tipped Set Screw located in the side of the Index Ring until the Index Ring rotates freely.

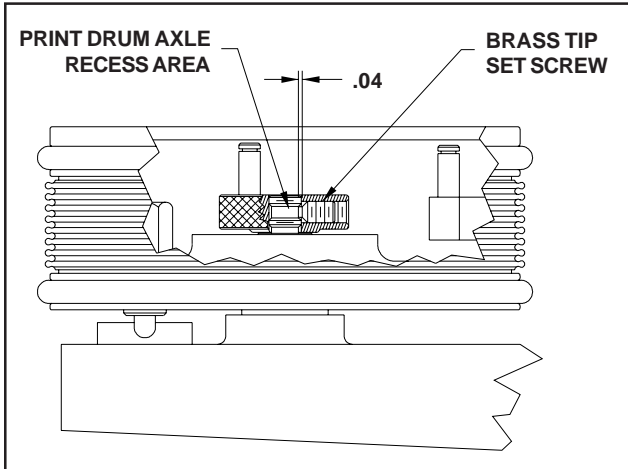

FIGURE 62

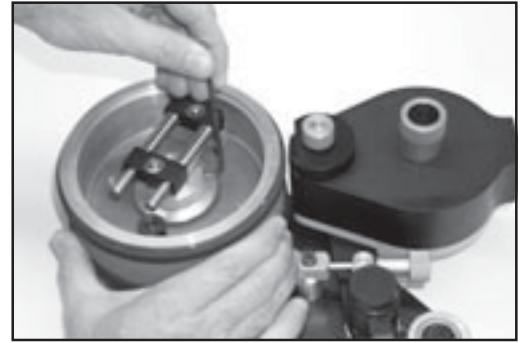

FIGURE 61

Important Note: The Print Drum Axle is machined with thread relief as shown in Figure 40 so the tip of the set screw will not damage the threads. To completely remove the Index Ring from the Axle, the Brass Tip Set Screw must be loosened at least 2 full turns to prevent damage to the threads.

- 6- Rotate the Index Ring in a clockwise direction until it stops turning. Next, turn the Index Ring in the counterclockwise direction as necessary until the Brass Tip Set Screw is pointing directly at the Transfer Roll Axle as shown in Figure 63.

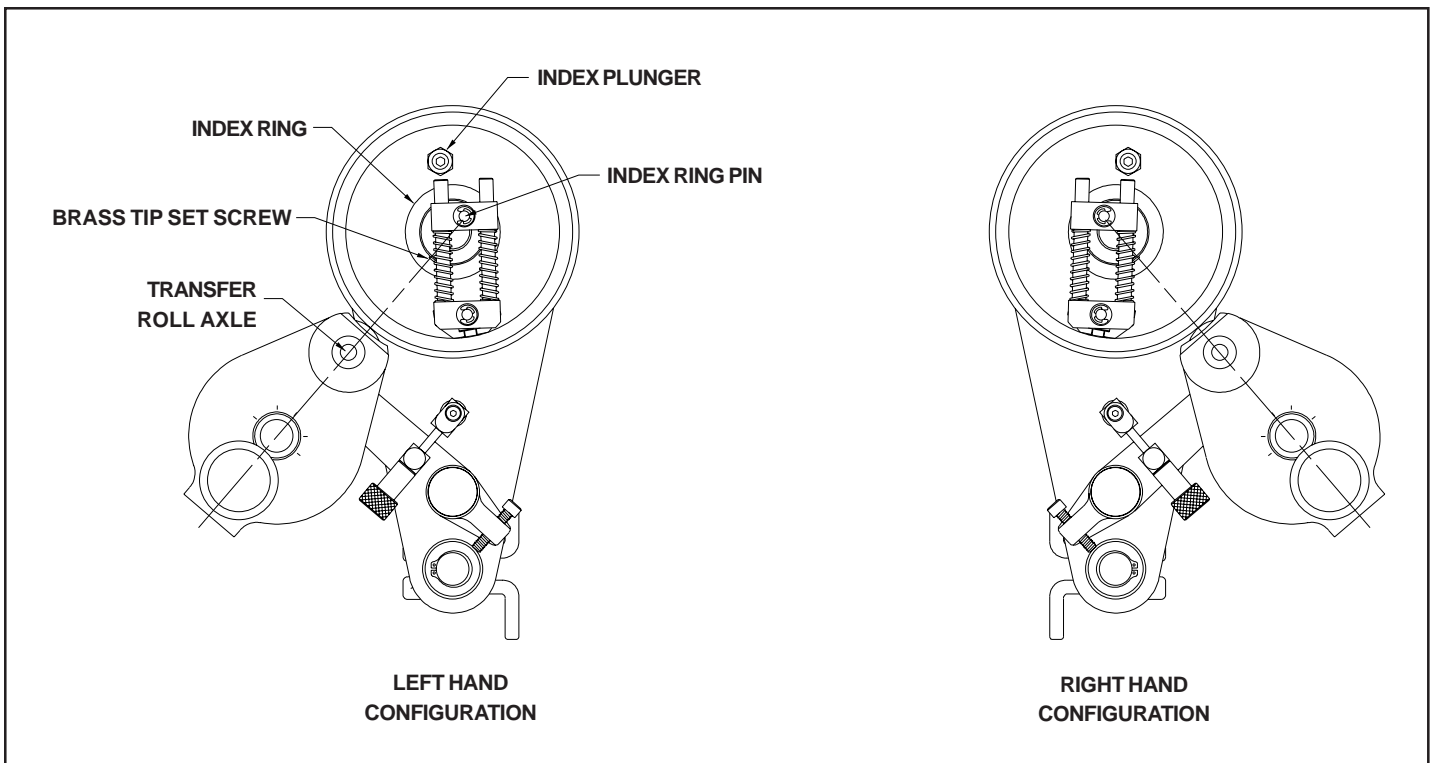

FIGURE 63

- 7- Retighten the Brass Tipped Set Screw to lock the Index Ring in position. This screw must be tight to prevent the Index Ring from rotating under spring tension.

MAINTENANCE

8- Reinstall the Index Ramp in the proper orientation for your mounting configuration as shown in Figures 64 & 65.

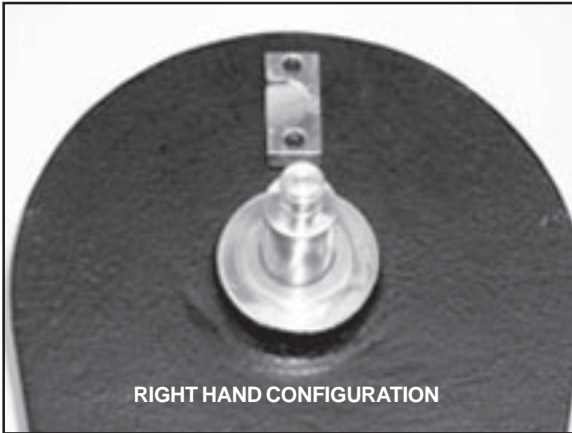

FIGURE 64

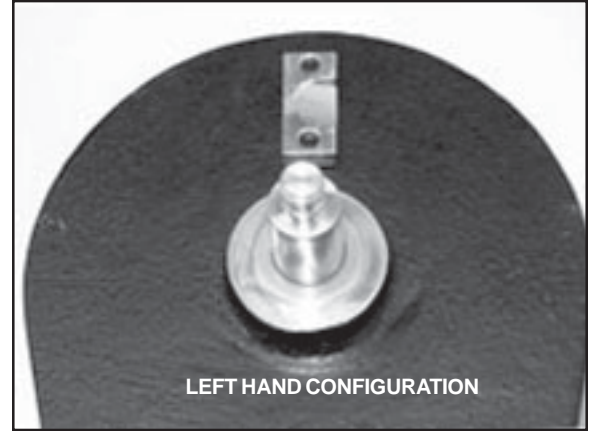

FIGURE 65

REPLACING PRINT DRUM INDEX SPRINGS

1- To replace Print Drum Index Springs, rotate the Print Drum approximately 3/4 turn to relieve spring tension as shown in Figure 59, Page 32.

2- Using a small screwdriver, remove the two Snap Rings on the Index Spring Assembly.



FIGURE 66

3- Remove the Index Spring Assembly by lifting it straight up off the pivot pins.



FIGURE 67

MAINTENANCE

- 4- Holding onto the Index Assembly Block “A”, pull the Index Assembly Block “C” off the guide shafts (Figure 68). Remove the Drum Index Springs (Figure 69)

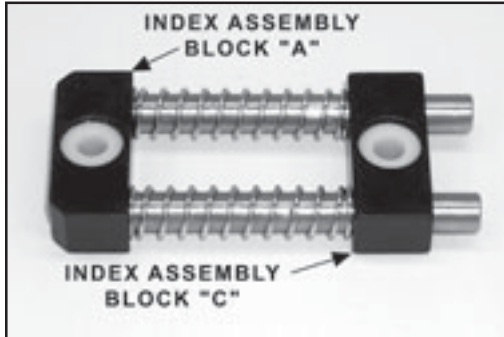

FIGURE 68



FIGURE 69

- 5- Install new Index Springs over the stainless steel guide shafts and replace Index Block “C”.

Ensure that Block “C” is installed in the same orientation as Block “A” with the flange of the white bushing (the large diameter end) facing in the same direction.

- 6- Reinstall the Index Spring Assembly in the Print Drum with the flanges of the white bushings facing the open end of the Print Drum.

- 7- Reinstall the two Snap Rings.

REMOVING AND REPLACING INDEX BLOCK “B”

- 1- To remove Index Block “B” from the Print Drum, roll down the Drum Cover directly behind the Index Block to expose the Index Assembly Mounting Screw. Using a screw driver, turn the Mounting Screw in a *clockwise* direction until the Index Block becomes loose and can be removed.



FIGURE 70

MAINTENANCE

2- Lift Index Block “B” straight up to remove.

The head of the Index Assembly Mounting Screw engages the T-Slot in Index Block “B”. This mounting design facilitates height adjustment of the Index Block during reassembly.



FIGURE 71

Before replacing Index Block “B”, ensure that the Index Ring is properly adjusted as explained in Steps 5 - 7 on Page 33.

3- When replacing Index Block “B” it is very important to align the top surface of the Index Block with the top surface of the Index Ring as shown in Figure 72.

The easiest way to accomplish this is to hold a flat block of metal or wood across the top of the Index Ring. While holding the block in place, raise Index Block “B” up to contact the bottom of the alignment block. Ensure that Block “B” is level and vertically aligned with the Index Ring.



FIGURE 72

4- While holding Index Block “B” in this position, tighten the Index Assembly Mounting Screw by turning it *counterclockwise* until tight.



FIGURE 73

MAINTENANCE

INKING SYSTEM ASSEMBLY

The following steps will guide you through the *Ink Roll Eccentric Assembly*.

- 1 - Install the O-Ring in the groove of the Eccentric flange, then install one of the white delrin washers on the Eccentric.

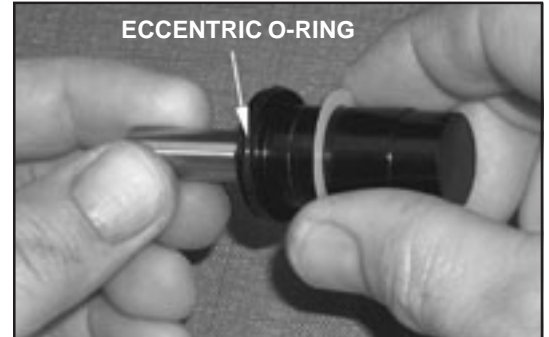

FIGURE 74

- 2 - Apply a thin coating of grease to the O-Ring and the Eccentric to approximately 1/2" from the flange.

Automotive wheel bearing grease is recommended.



FIGURE 75

- 3 - Insert the Eccentric into the Inking System Cover. Rotate and pull the Eccentric from the opposite side until the o-ring slips into the bore. When fully seated, the flange of the eccentric will be approximately 0.010" above the surface of the cover. Rotate the Eccentric and align the dimple on the Eccentric flange with the dimple in the cover.

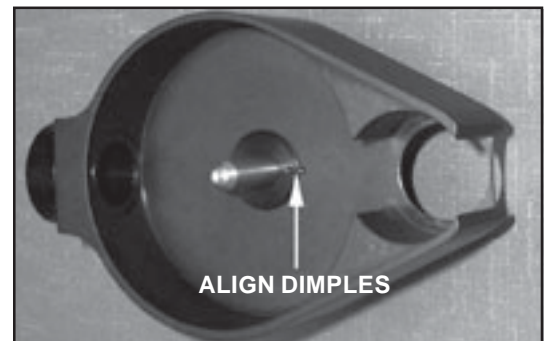

FIGURE 76

- 4 - Install the second white delrin washer over the Eccentric.



FIGURE 77

MAINTENANCE

- 5 - Install the Eccentric Knurled Knob and align the engraved line on the knob with the “MAX” line on the Inking System Cover. Set the ink roller axle on a small block of wood or metal . The block used should be tall enough so the entire assembly is supported by the ink roller axle (the Inking System Cover should not touch the table top).



FIGURE 78

- 6 - Press down firmly on the Eccentric Knurled Knob. While holding pressure on the knob, tighten the two set screws.

When adequate pressure is applied to the Eccentric Knob during assembly, the knob should have a moderate resistance to turning. When assembled properly, the ink roller axle should be feel rigid.



FIGURE 79

NON-POROUS CONVEYOR LINE PRINTER CE GUARD ASSEMBLY
CLP-100 & CLP-200 SERIES

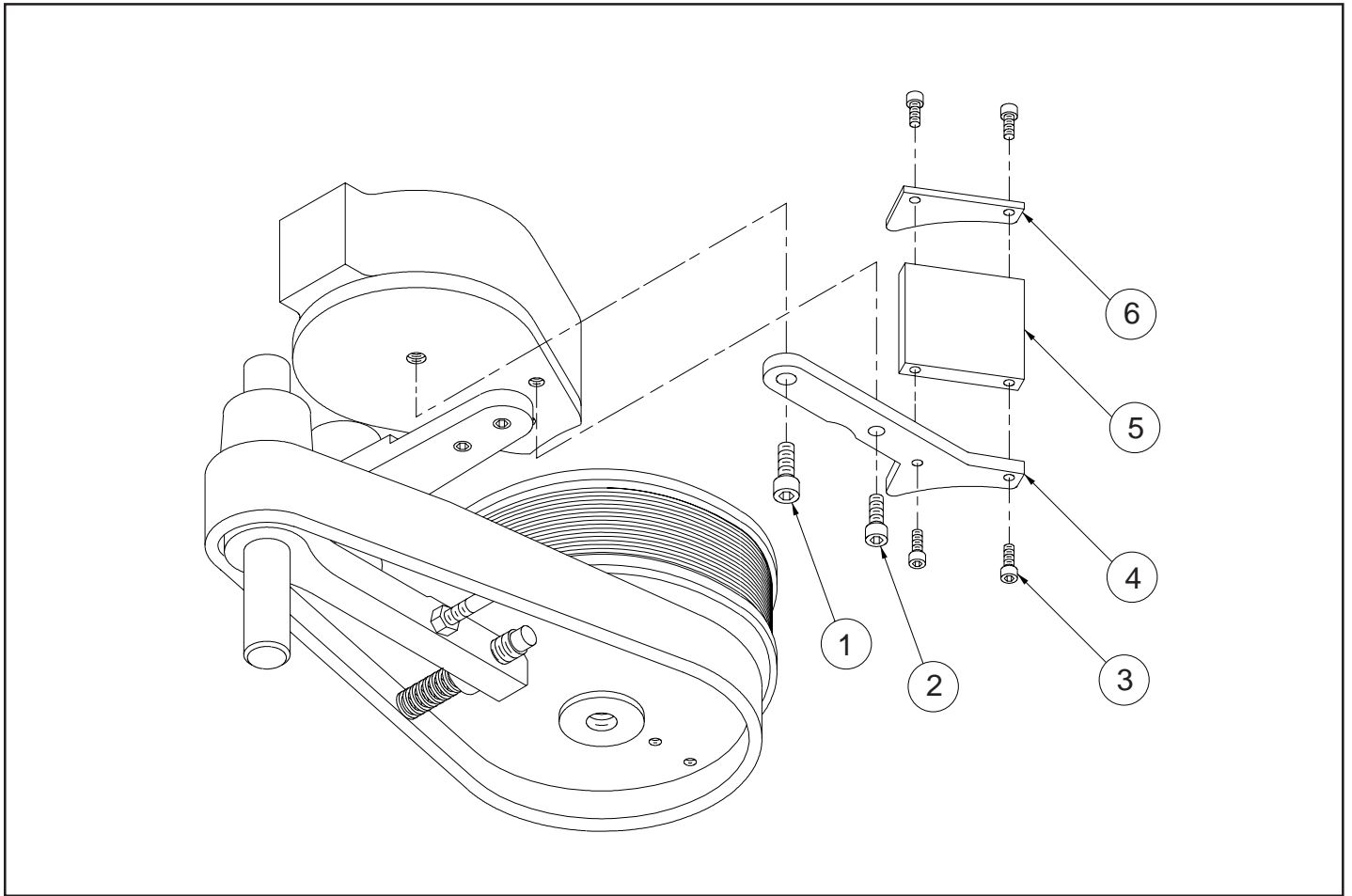

**NON-POROUS CONVEYOR LINE PRINTER
 CE GUARD ASSEMBLY PARTS LIST**

KEY NO.	PART NUMBER	QTY. REQD.	DESCRIPTION
1	CF-32	1	SCREW, 5/16-18 X 1/2" SHC
2	NP-23	1	SCREW, 1/4-20 X 1/2" SHC
3	MS-36	4	SCREW, 8-32 X 1/2" SHC
4	NP-70	1	MOUNTING ARM, CLP CE GUARD
5	NP-72	1	TOP PLATE, #100 CLP CE GUARD
	NP-73		TOP PLATE, #200 CLP CE GUARD
6	NP-71	1	END PLATE, CLP CE GUARD

NON-POROUS CONVEYOR LINE PRINTER

CLP-100 & CLP-200 SERIES

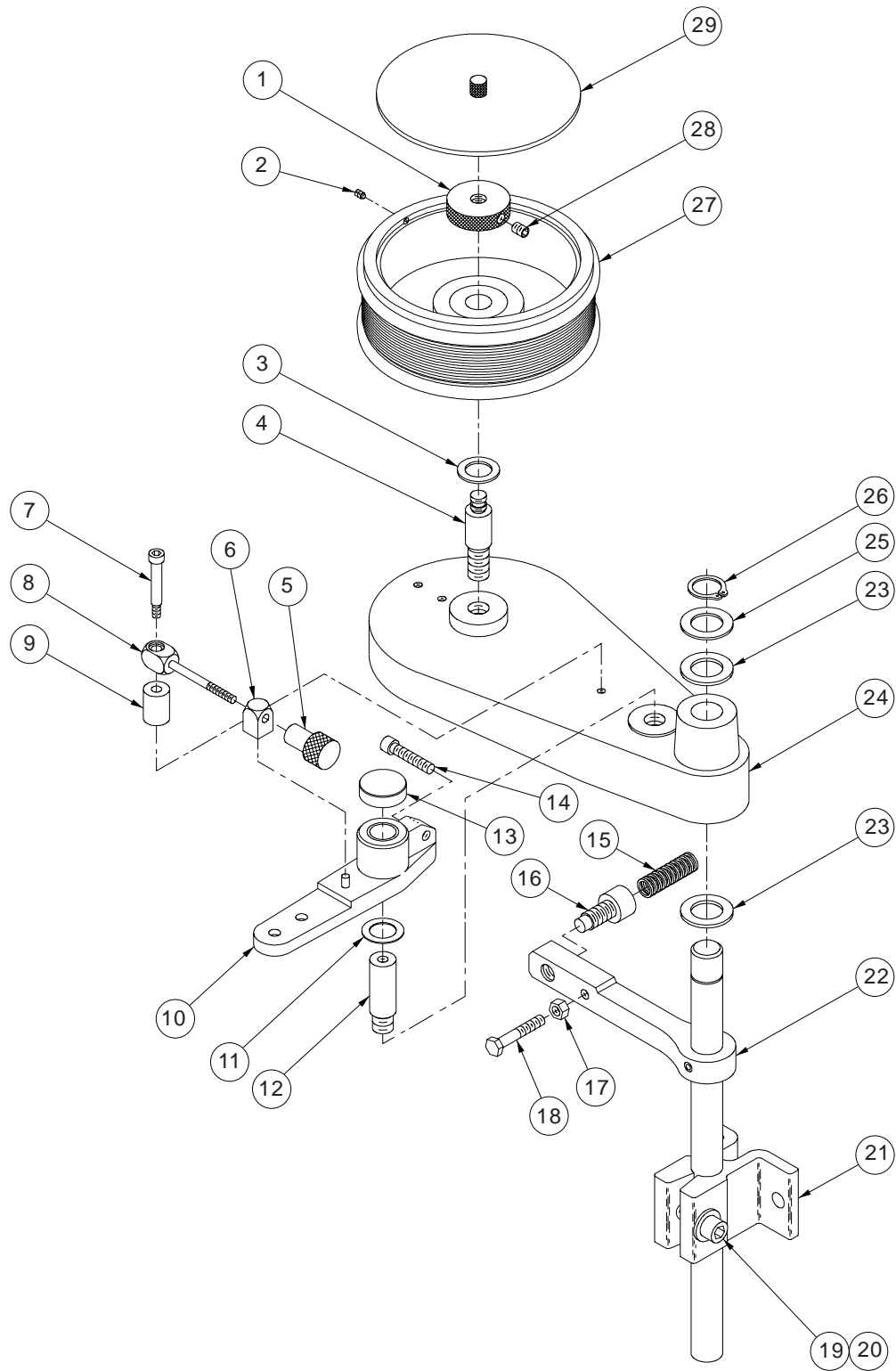

NON-POROUS CONVEYOR LINE PRINTER PARTS LIST

KEY NO.	PART NUMBER	QTY. REQD.	DESCRIPTION
1	CM-04	1	KNURLED RETAINING RING
2	CF-05	1	SET SCREW, 8-32 X 3/16" S.S. NPS
3	CW-03	1	WASHER, PRINT DRUM BRASS
4	CA-06	1	PRINT DRUM AXLE - 1"
	CA-02	1	PRINT DRUM AXLE - 2"
5	NP-18	1	KNOB, PIVOT ARM ADJUSTMENT
6	CM-27	1	BLOCK "A" PIVOT ARM
7	CF-26	1	SHOULDER SCREW
8	CLP-PAB	1	BLOCK "B" ASSEMBLY, PIVOT ARM
9	CM-26	1	PIVOT ARM POST
10	NP-28	1	PIVOT ARM ASSEMBLY, NON-POROUS
11	CW-04	1	WASHER, PIVOT ARM BRASS
12	CA-03	1	AXLE, PIVOT ARM
13	CM-16	1	CAP, PIVOT ARM
14	CF-02	1	SCREW, 1/4-20 X 1-1/4" SHC
15	CS-06	1	SPRING, TENSION ARM COMPRESSION
16	CM-25	1	TENSION ARM ADJUSTING CUP
17	CF-11	1	HEX NUT
18	CF-10	1	HEX BOLT
19	CF-09	1	SCREW, 3/8-16 X 1-1/2" SHC
20	CW-02	1	3/8" STEEL FLAT WASHER
21	CM-17	1	MOUNTING BRACKET
22	CLP-MCA	1	MOUNTING COLUMN ASSEMBLY
23	CW-05	2	3/4" NYLON FLAT WASHER
24	CC-01	1	BASE PLATE ASSEMBLY
25	CW-01	1	3/4" STEEL FLAT WASHER
26	CF-13	1	SNAP RING, FOR 3/4" SHAFT
27	CLP-100NI-NP-PDA	1	1" NON-INDEXING PRINT DRUM ASSEMBLY - COMPLETE
	CLP-100NP-PDA	1	1" INDEXING PRINT DRUM ASSEMBLY - COMPLETE
	CLP-200NI-NP-PDA	1	2" NON-INDEXING PRINT DRUM ASSEMBLY - COMPLETE
	CLP-200NP-PDA	1	2" INDEXING PRINT DRUM ASSEMBLY - COMPLETE
	CLP-100NI-NP-PDA-T	1	1" NON-INDEXING PRINT DRUM ASSEMBLY - COMPLETE - METRIC
	CLP-100NP-PDA-T	1	1" INDEXING PRINT DRUM ASSEMBLY - COMPLETE - METRIC
	CLP-200NI-NP-PDA-T	1	2" NON-INDEXING PRINT DRUM ASSEMBLY - COMPLETE - METRIC
	CLP-200NP-PDA-T	1	2" INDEXING PRINT DRUM ASSEMBLY - COMPLETE - METRIC
28	CF-04	1	SET SCREW, 1/4-20 X 3/8" BTS
29	CM-13	1	DUST COVER

NON-POROUS CONVEYOR LINE PRINTER INKING SYSTEMS

CLP-100 & CLP-200 SERIES

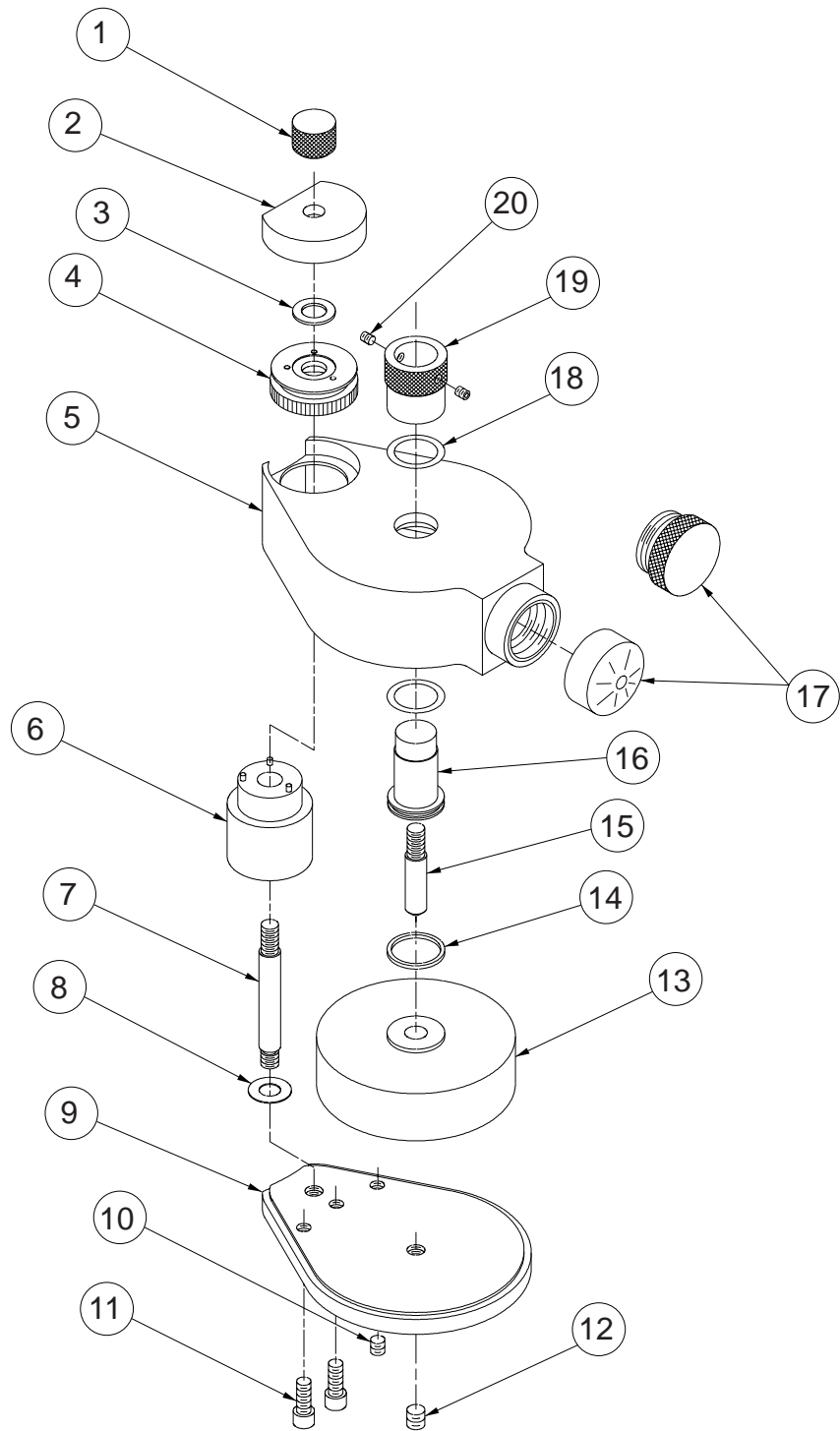

NON-POROUS CONVEYOR LINE PRINTER INKING SYSTEM PARTS LIST

KEY NO.	PART NUMBER	QTY. REQD.	DESCRIPTION
1	NP-17	1	COVER RETAINING KNOB
2	NP-16	1	DRIVE WHEEL COVER
3	NP-15	1	DELTRIN WASHER, DRIVE WHEEL
4	NP-14	1	KNURLED DRIVE WHEEL ASSEMBLY W/NP-15 DELTRIN WASHER
5	NP-01-CS	1	INKING SYSTEM COVER ASSEMBLY - SIDE MOUNT - CLP-100 SERIES
	NP-01-CT		INKING SYSTEM COVER ASSEMBLY - TOP MOUNT - CLP-100 SERIES
	NP-02-CS		INKING SYSTEM COVER ASSEMBLY - SIDE MOUNT - CLP-200 SERIES
	NP-02-CT		INKING SYSTEM COVER ASSEMBLY - TOP MOUNT - CLP-200 SERIES
6	NP-TRA-1	1	1" TRANSFER ROLL ASSEMBLY
	NP-TRA-2		2" TRANSFER ROLL ASSEMBLY
7	NP-05	1	1" CLP TRANSFER ROLL AXLE
	NP-06		2" CLP TRANSFER ROLL AXLE
8	HP-04	1	BRASS WASHER, PRINT DRUM
9	NP-03	1	CLP NON-POROUS INKING SYSTEM BASEPLATE
10	NP-31	1	SET SCREW, 1/4-20 X 3/8" FPS
11	NP-23	1	SCREW, 1/4-20 X 1/2" SHC
12	NP-24	1	SET SCREW, 5/16-18 X 3/8" FPS
13	NP-XC1	1	1" CLP XF NEOPRENE INK ROLL - DRY
	NP-XC2		2" CLP XF NEOPRENE INK ROLL - DRY
14	NP-21	1	O-RING, ECCENTRIC
15	NP-07	1	1" CLP INK ROLL AXLE
	NP-08		2" CLP INK ROLL AXLE
16	NP-20C	1	ECCENTRIC, INK ROLL
17	NP-29	1	BLACK VINYL CAP
	*NP-KRP		KNURLED RESERVOIR PLUG
18	HP-42	2	DELTRIN WASHER
19	NP-19	1	ECCENTRIC KNURLED KNOB
20	HP-06	2	SET SCREW, 8-32 X 3/16" CPS

*OPTIONAL THREADED PLUG WITH O-RING SEAL FOR RESERVOIR PORT

NON-POROUS CONVEYOR LINE PRINTER PRINT DRUM ASSEMBLY

CLP-100 & CLP-200 SERIES

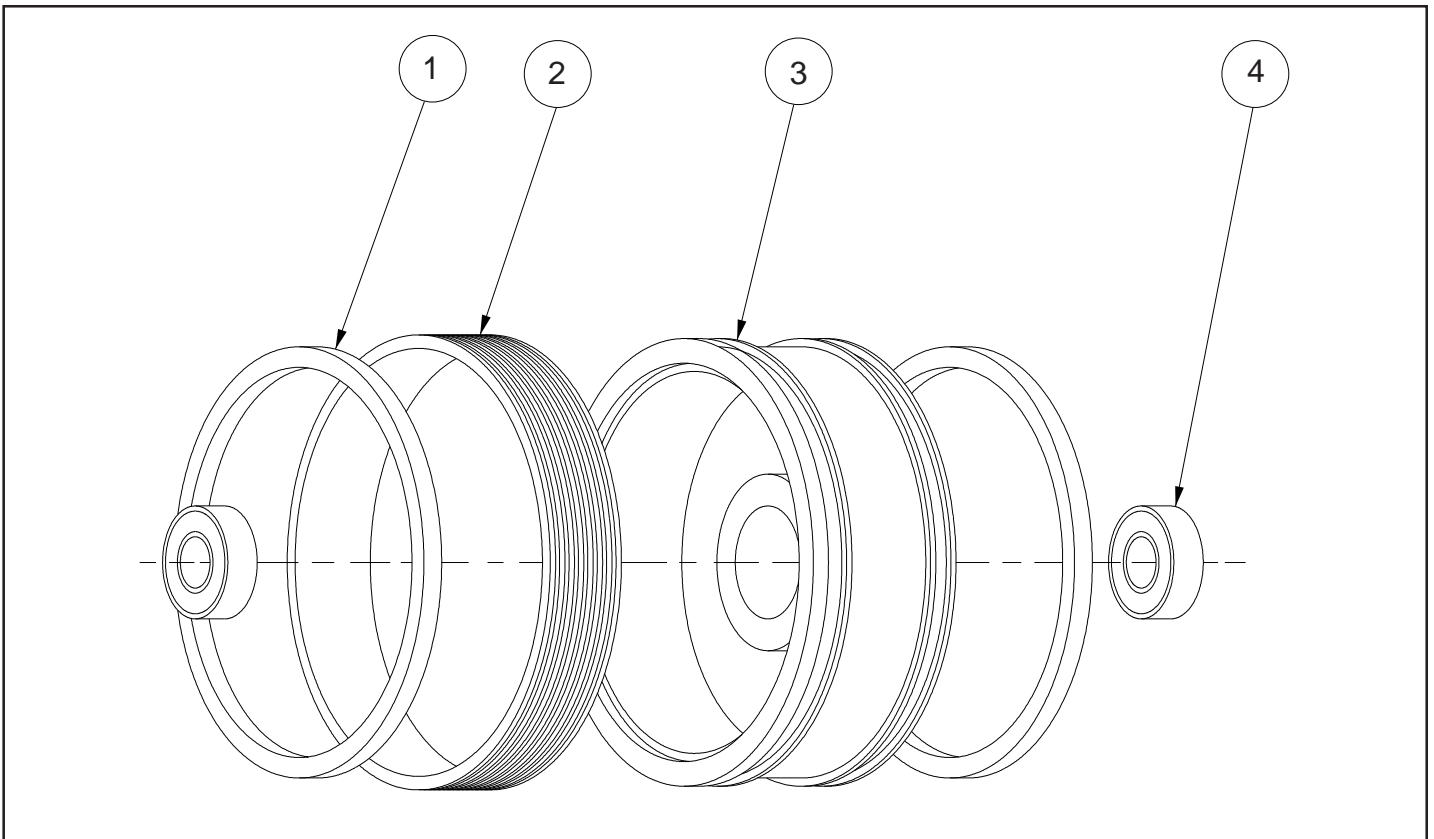

NON-POROUS CONVEYOR LINE PRINTER PRINT DRUM ASSEMBLY PARTS LIST

KEY NO.	PART NUMBER	QTY. REQD.	DESCRIPTION
1	CO-02S	2	FRICITION BEARER RING - SQUARE CUT
2	CLP-BL1	1	1" CLP RIBtype® RING
	CLP-BL2		2" CLP RIBtype® RING
	CLP-BL1T		1" CLP RIBtype® RING - METRIC
	CLP-BL2T		2" CLP RIBtype® RING - METRIC
3	CLP-PD1-NP	1	CLP-100 NON-INDEXING PRINT DRUM (W/CB-04 PRINT DRUM BEARINGS)
	CLP-PD1I-NP		CLP-100 INDEXING PRINT DRUM (W/CB-04 PRINT DRUM BEARINGS)
	CLP-PD2-NP		CLP-200 NON-INDEXING PRINT DRUM (W/CB-04 PRINT DRUM BEARINGS)
	CLP-PD2I-NP		CLP-200 INDEXING PRINT DRUM (W/CB-04 PRINT DRUM BEARINGS)
	CLP-PD1-NPT		CLP-100 NON-INDEXING PRINT DRUM (W/CB-04 PRINT DRUM BEARINGS) - METRIC
	CLP-PD1I-NPT		CLP-100 INDEXING PRINT DRUM (W/CB-04 PRINT DRUM BEARINGS) - METRIC
	CLP-PD2-NPT		CLP-200 NON-INDEXING PRINT DRUM (W/CB-04 PRINT DRUM BEARINGS) - METRIC
	CLP-PD2I-NPT		CLP-200 INDEXING PRINT DRUM (W/CB-04 PRINT DRUM BEARINGS) - METRIC
4	CB-04	2	PRINT DRUM BEARING

NON-POROUS CONVEYOR LINE PRINTER INDEX ASSEMBLY

CLP-100 & CLP-200 SERIES

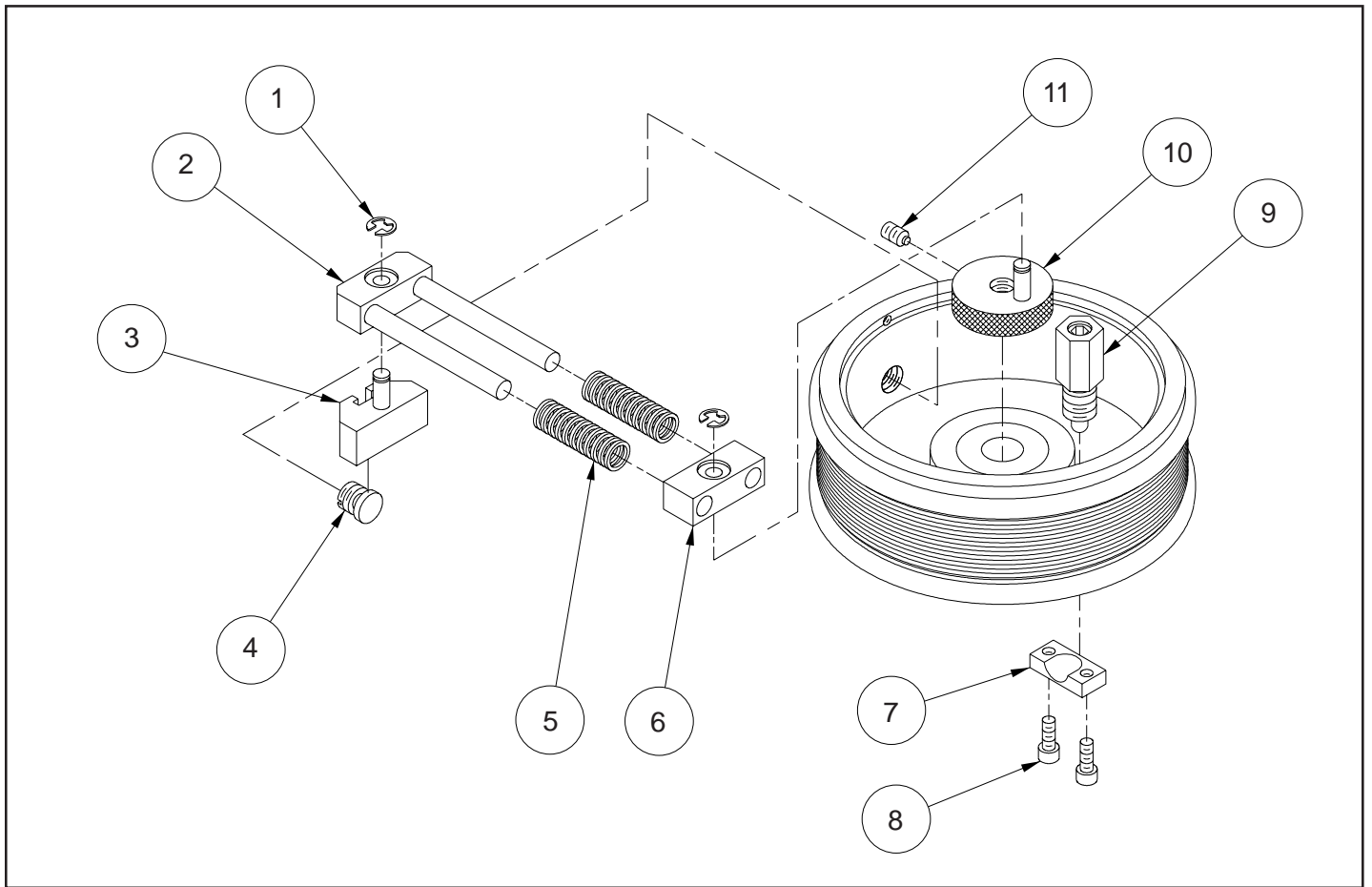

NON-POROUS CONVEYOR LINE PRINTER INDEX ASSEMBLY PARTS LIST

KEY NO.	PART NUMBER	QTY. REQD.	DESCRIPTION
1	CF-28	2	SNAP RING
2	CLP-IA	1	INDEX ASSEMBLY BLOCK "A"
3	CLP-IB	1	INDEX ASSEMBLY BLOCK "B"
4	CF-27	1	INDEX ASSEMBLY MOUNTING SCREW
5	CS-07	2	DRUM INDEX SPRING
6	CLP-IC	1	INDEX ASSEMBLY BLOCK "C"
7	CM-34	1	INDEX RAMP
8	CF-29	2	SCREW, 10-32 X 1/2" SHC
9	CLP-IP	1	INDEX PLUNGER ASSEMBLY
10	CLP-IR2	1	INDEX RING
11	CF-04	1	SET SCREW, 1/4-20 X 3/8" BTS