



**OWNER'S MANUAL**

**NON-POROUS  
HAND PRINTERS  
ALL MODELS**

**OPERATION - MAINTENANCE**



**UNIVERSAL STENCILING & MARKING SYSTEMS, INC.**

P.O. BOX 871 - ST. PETERSBURG, FLORIDA 33731 USA

PH: (727) 894-3027 FAX: (727) 821-7944

E-Mail: [sales@universal-marking.com](mailto:sales@universal-marking.com) Website: [www.universal-marking.com](http://www.universal-marking.com)

**HPNP-10013**

---

---

## **IMPORTANT NOTE**

---

---

UNIVERSAL products are manufactured to exacting standards and every available step has been taken to assure your complete satisfaction. It is most important, however, that the instructions contained in this manual are read and carefully followed for best results. Failure to do so may result in unsatisfactory performance, damage to the equipment and personal injury.

### **TABLE OF CONTENTS**

|  |    |
|--|----|
| PREFACE . . . . .  | 3  |
| SPECIFICATIONS . . . . .   | 4  |
| HPNP-100, HPNP-100NI, HPNP-100-T & HPNP-100NI-T . . . . .          | 4  |
| Indexing & Non-Indexing models . . . . .                           | 5  |
| Printing Dies . . . . .  | 6  |
| Ink Rolls . . . . .  | 7  |
| QUICK START . . . . .  | 8  |
| Installing the Pre-Inked Roll . . . . .                            | 8  |
| Installing the Printing Dies . . . . .                             | 11 |
| Adjusting the Die Position on Indexing Printers . . . . .          | 12 |
| Adjusting the Ink Roll Eccentric . . . . .                         | 13 |
| BASIC PRINCIPLES OF OPERATION . . . . .                            | 14 |
| Inking System Design . . . . .                                     | 14 |
| Ink Options . . . . .  | 14 |
| MAINTENANCE . . . . .  | 15 |
| Pre-inking the XF Neoprene Ink Roll . . . . .                      | 15 |
| Cleaning the Printing Dies . . . . .                               | 17 |
| Cleaning the Transfer Roll . . . . .                               | 18 |
| Cleaning the Coder . . . . .                                       | 18 |
| Coder Assembly Notes . . . . .                                     | 19 |
| Adjusting the Transfer Roll to Die Face Contact Pressure . . . . . | 19 |
| Install the Index Assembly . . . . .                               | 20 |
| PARTS LIST & DIAGRAMS . . . . .                                    | 22 |

### **- LIMITED WARRANTY -**

UNIVERSAL Non-Porous Hand Printers are guaranteed to be free from defects in materials and workmanship for a period of 90 days from the date of purchase. Components found to be defective during this time will be repaired free of charge if returned to the factory. Damage resulting from use of improper inks, improper installation, or operation is not covered under the scope of this warranty. For warranty service please contact our Customer Service Department.

## **PREFACE**

Printing on non-porous materials has always been a major problem in industrial applications. The high degree of maintenance usually required to keep conventional "non-porous" machines operating has made many companies opt for manual marking as a cost effective alternative. UNIVERSAL changed all that with our patented Non-Porous Inking System design. Previously available only on conveyor line mounted coders, this same technology is now available on the new Universal Non-Porous Hand Printers.

Printing on non-porous materials can now be accomplished with the same relative ease as printing on porous materials. This breakthrough in Non-Porous coder design opens up in-plant printing opportunities which previously were regarded as too difficult to consider.

Unlike the inks used to print on porous materials which dry through absorption into the material being printed, non-porous inks rely on the rapid evaporation of the ink solvents to achieve fast drying of the printed marks. Since the ink solvents must evaporate very rapidly on the printed material, they also evaporate very rapidly from the ink rolls and ink wells of conventional printers therefore requiring constant maintenance.

The proprietary design of the UNIVERSAL Non-Porous Inking System effectively eliminates the rapid evaporation of the ink solvents from the ink roll. The final design of this system was the product of many months of design engineering and field testing. The final product is both simplistic in design and extremely effective in operation. The relatively low cost of these systems makes in-plant printing of all types of non-porous materials a practical reality. The following pages of this manual explain the operation and maintenance of the Non-Porous Hand Printers and are the key to trouble free non-porous printing.

### **QUICK START PAGES 8 THRU 13**

This manual was written with a full understanding that very few people like to read manuals or have the time to do so. To accommodate those who have little time to spare, we have included a Quick Start section which will get your coder operating in just a few minutes.

To keep your coder operating properly, it is important to read and understand the Basic Principles of Operation section which explains the basic operation of the Non-Porous Inking System.

## **CODER SPECIFICATIONS**

The following specification diagram includes the basic dimensions of the Non-Porous Hand Printers. The approximate net weights, maximum die capacities, maximum print width and print drum circumferences are also listed for reference.

# SPECIFICATIONS

## NON-POROUS HAND PRINTER SPECIFICATIONS

HPNP-100, HPNP-100NI, HPNP-100-T, HPNP-100NI-T

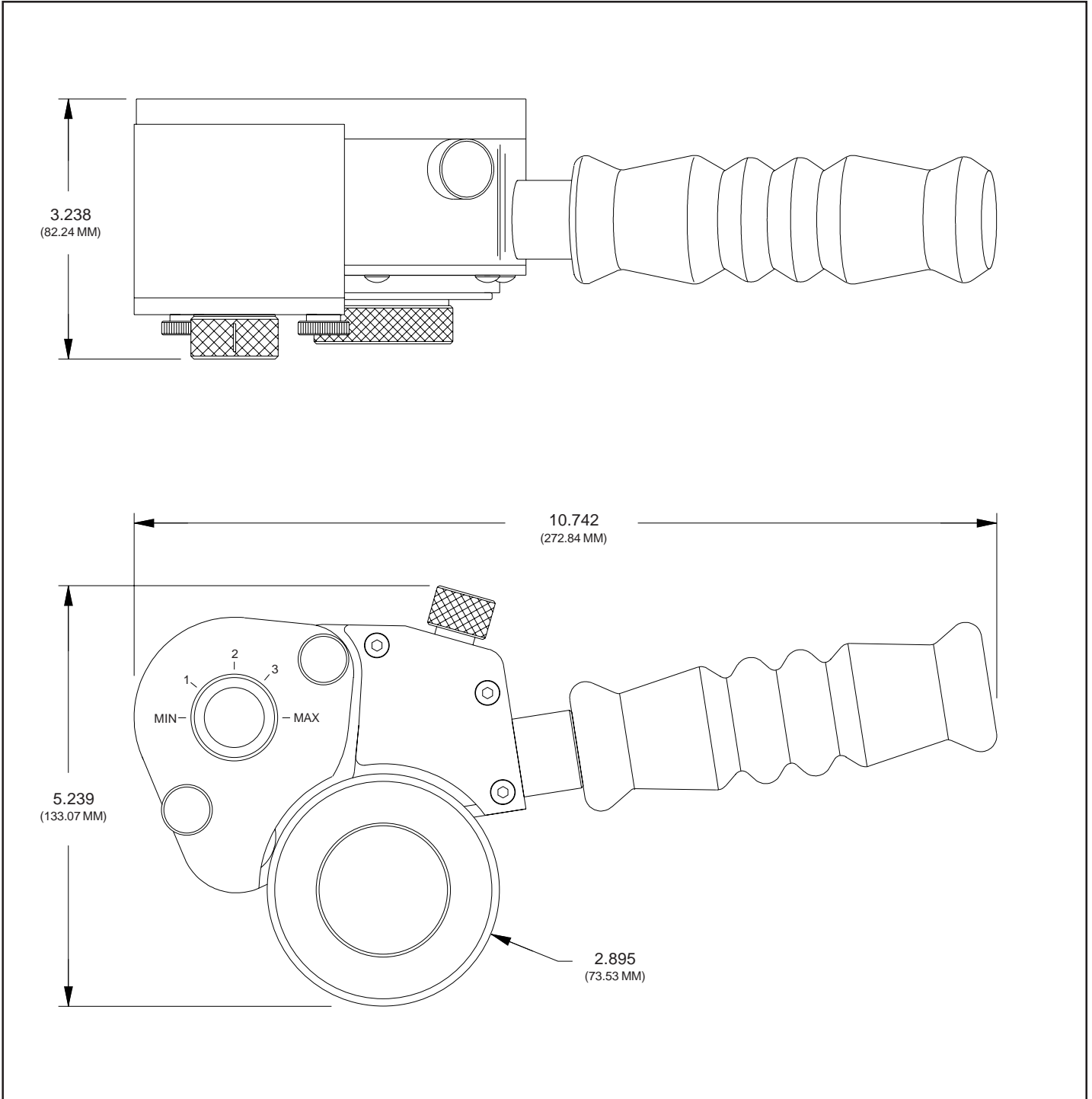

NET WEIGHT:

MAXIMUM DIE SIZE - US STANDARD:

MAXIMUM DIE SIZE - METRIC CODERS ONLY:

PRINT DRUM CIRCUMFERENCE:

9 LBS. - 8 OZS. (4.31 KG.)

7/8" (8 RIBS) X 8-3/8" LENGTH

23.8 MM (7 RIBS) X 212.7MM LENGTH

APPROXIMATELY 9.1" (231 MM) MEASURED AT DIE FACE

---

---

# SPECIFICATIONS

---

---

## INDEXING & NON-INDEXING MODELS

Universal Non-Porous Hand Printers are available from the factory in both indexing and non-indexing models. Indexing Hand Printers contain a cam & spring return mechanism (see Figure 1) which returns the print drum to the same rotational position after every imprint is applied. This feature provides print registration capabilities when printing on cut sheets of material or the sides of varnished or waxed cartons.

Non-Indexing Hand Printers have print drums which simply rotate on bearings and repeat the print at an interval equal to the circumference of the print drum. If repeat intervals shorter than the print drum circumference are required, duplicate sets of dies can be installed on the print drum. Non-Indexing Hand Printers are generally used for printing on long lengths of material where it is desirable to print the same code repeatedly down the entire length of material.

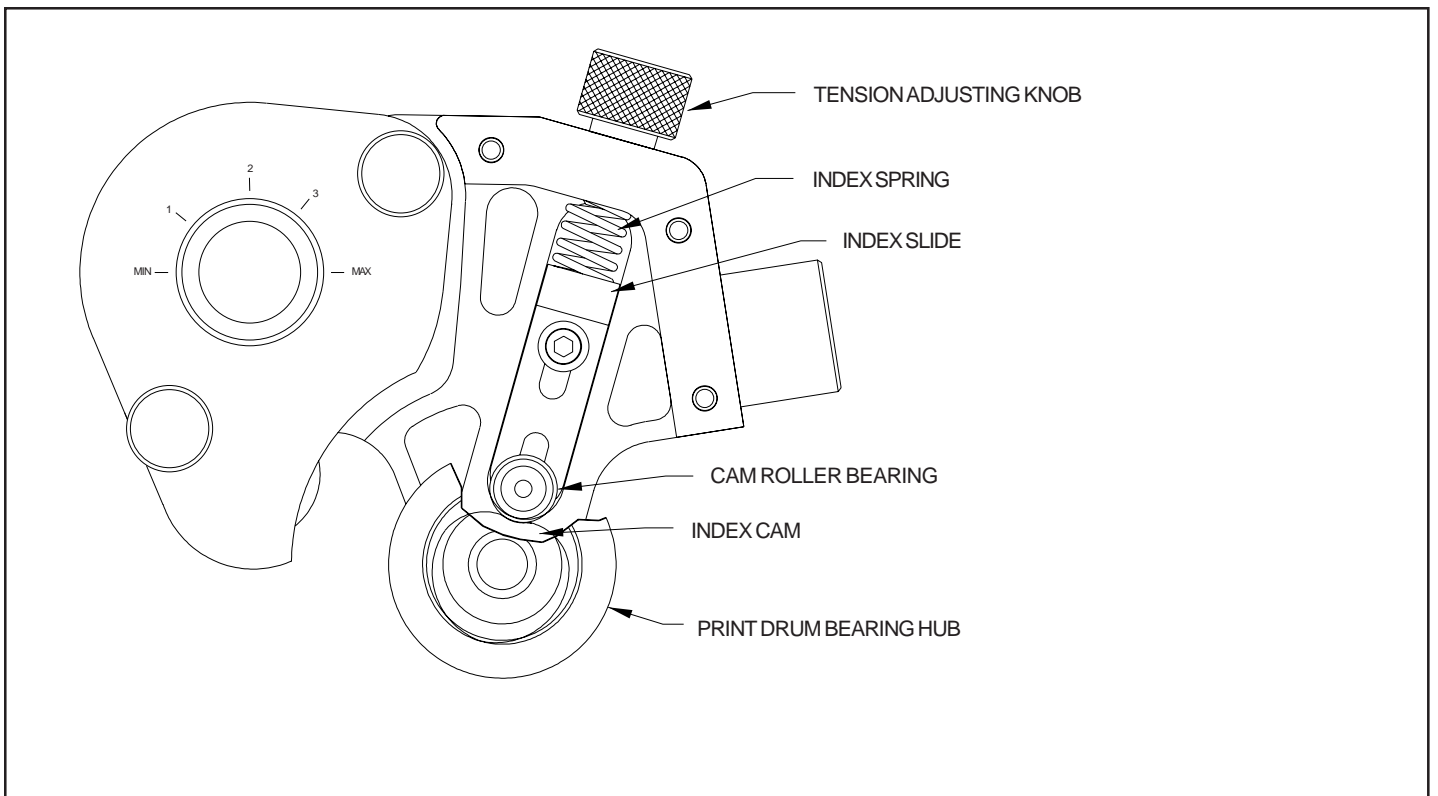

FIGURE 1

---

---

## SPECIFICATIONS

---

---

### **RIBtype® PRINTING DIES**

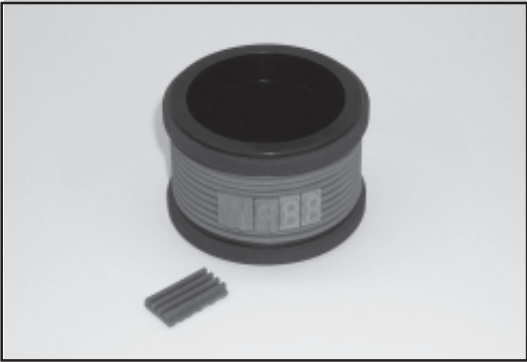

FIGURE 2

Universal Non-Porous Hand Printers are designed to use Universal RIBtype® rubber printing dies which have a molded rib backing. The ribs on the back of the die snap into mating ribs in the Drum Cover on the print drum as shown.

These printing dies are available in many standard character styles and sizes and come in sets containing a combination of individual alphabetic and numeric characters or in sets containing numeric characters only. These character sets or “sorts” can be used to make up text messages and code numbers as necessary.

Printing dies are also available in “logo” form in which a complete text message is produced on a single piece of rib backed rubber. Logo dies are much faster to change and generally produce better print quality since they are more dimensionally stable than individual characters when installed on the print drum. Custom type styles, company logos, and trademarks can also be photographically reproduced from black and white art work. The cost of producing custom dies from original art work is slightly more expensive than using standard type styles but it offers the user the ability to maintain product identity consistent with marketing efforts. For details on ordering custom logo dies, please contact our Customer Service Department.

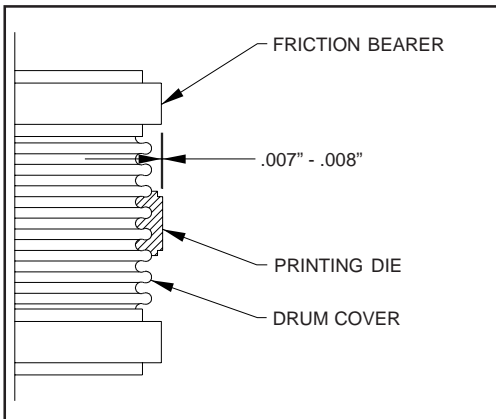

FIGURE 3

Universal RIBtype® dies are manufactured to precision thickness tolerances which are very critical to the proper function of these machines. When installed, the face of the printing die should extend only .007" - .008" beyond the radius of the Friction Bearers. Using dies that do not meet the design specifications will result in poor print quality and possible damage to the transfer roll.

***Although there are several competitive rib backed die systems available, it is very important to note that they are not all made to the same specifications and they are not interchangeable.***

### **CODER MODELS DESIGNED FOR METRIC RIBtype® PRINTING DIES**

Universal also offers Metric RIBtype® die systems for use in countries where metric character sizes are the standard. The Metric dies are thicker and the rib spacing differs slightly from the standard printing dies therefore the two versions are not compatible. To accommodate the differences, the print drums for Metric dies are machined to a slightly different diameter from the U.S. versions.

The coder model numbers on Metric coders will have a “-T” suffix and the Metric RIBtype® Drum Covers have a distinct pink color.

---

---

# SPECIFICATIONS

---

---

## INK ROLLS

Universal offers two ink roll options for the Non-Porous Hand Printers. The coders are designed to accommodate both types of ink rolls without modification. A detailed review of your printing requirements will determine the best choice of ink rolls for your particular application.

### ***XF NEOPRENE INK ROLLS***

Universal's XF Neoprene Ink Rolls are a re-inkable roll which can be used with a variety of alcohol or glycol base inks. These rolls are normally supplied in a dry condition with the coder and require ***pre-inking*** prior to installation. Pre-inked rolls are available from the factory and are recommended for first time users.

Universal's #100 Inks provide drying times of approximately 2 seconds at 75 Degree F. (24 Deg. C) ambient temperature. Many other inks, both dye and pigment based, can be used in these ink rolls to meet the specific application requirements. Refer to the Basic Principles of Operation section on Page 14 for more information on selecting an appropriate ink.



FIGURE 4

### ***TYPE MT INK ROLLS***

Universal's Type MT Ink Rolls are disposable pre-inked rolls which are available in Black only. The MT Ink Rolls provide excellent color density and adhesion on most materials and yield a much greater number of impressions than the XF Neoprene Rolls before replacement is necessary.

The Type MT Ink Rolls provide drying times between 4 - 7 seconds at 75 Degree F. (24 Deg. C) ambient temperature. The added convenience and simplicity of using the Type MT Ink Rolls makes them an ideal choice in high volume production applications.



FIGURE 5

---

---

## QUICK START

---

---

**Warning:** *Non-Porous inks contain flammable solvents. Do not smoke or handle these rolls in the presence of sparks or open flames. Inks will also stain clothing, furniture, carpeting and your hands. Rubber gloves should be worn during the following procedures.*

### INSTALLING THE PRE-INKED ROLL

**The ink roll you install on the coder must be properly pre-inked.** If your coder was supplied with a dry XF Neoprene ink roll, refer to the Maintenance Section on page 15 for inking instructions.

Rollers that have been pre-inked at the factory are normally slightly oversaturated with ink to compensate for potential solvent loss during shipping and storage. If you received a pre-inked ink roll with your coder, it is important to examine the roll prior to installation. **The ink roll should be thoroughly saturated with ink but not dripping wet.** Excess ink can be easily removed by lightly rolling the ink roll across a clean piece of absorbent paper.

**1 - To install the pre-inked roll, first turn the Ink Roll Eccentric Adjusting Knob "A" to the "MIN" position.**

This moves the ink roller axle away from the Transfer Roll and enables the ink roll to be installed without interference with the Transfer Roll during reassembly of the inking system.

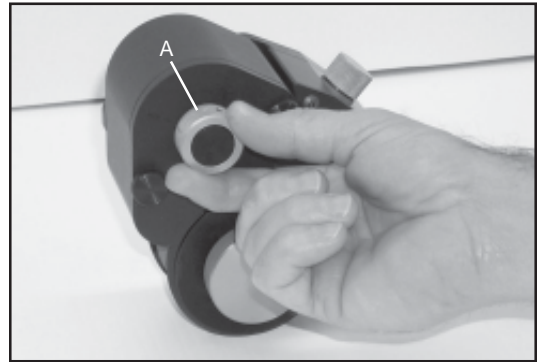

FIGURE 6

**2 - Remove the two cover retaining Thumbscrews "B".**

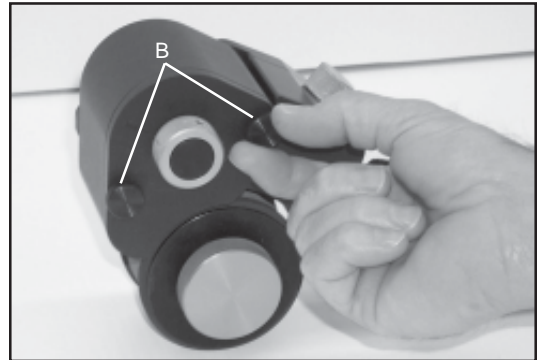

FIGURE 7

**3 - Remove the Inking System Housing Cover.**

The Ink Roller Core Assembly is installed on the Ink Roller Axle when shipped from the factory.

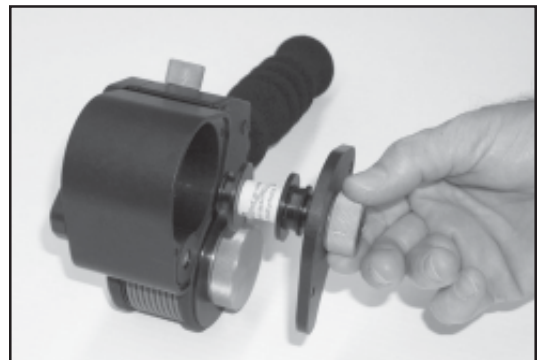

FIGURE 8

---

---

## QUICK START

---

---

### 4 - Remove the Core Assembly from the Ink Roller Axle.

Remove the Instruction Sheet from the Core.

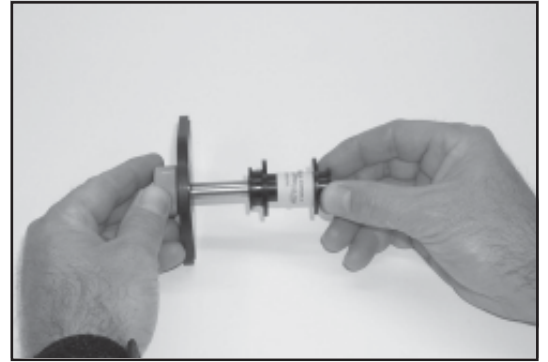

FIGURE 9

### 5 - Separate the two halves of the Core Assembly.

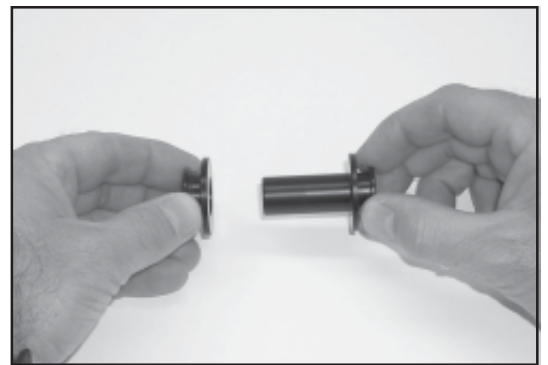

FIGURE 10

### 6 - Place the Pre-Inked Ink Roll on its side and push the Core into the center hole .

The ink roll you install on the coder must be Pre-Inked. If your ink roll is not saturated with ink refer to page 15 for inking instructions.



FIGURE 11

### 7 - Using the Core Hub, push the Ink Roll fully onto the Core.



FIGURE 12

---

---

## QUICK START

---

---

**8 - Inspect the Ink Roll closely for excess ink content. The roll should be fully saturated but not dripping wet. If the roller appears to be excessively wet, place a screwdriver through the core and roll the ink roll across a clean piece of paper or cardboard to remove excess ink.**

Installing an oversaturated ink roll on your coder will result in poor print quality and possible ink leakage problems.

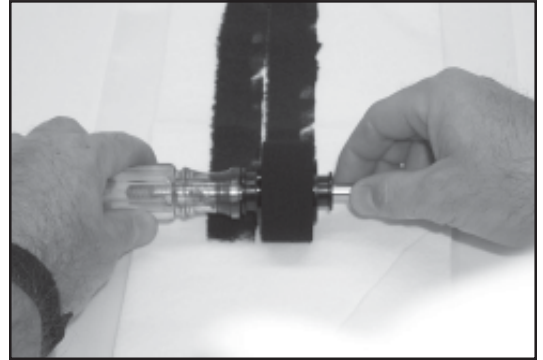

FIGURE 13

**9 - Install the Ink Roll assembly on the Ink Roll Axle.**

It does not matter which end of the Ink Roller Assembly goes on the axle first.

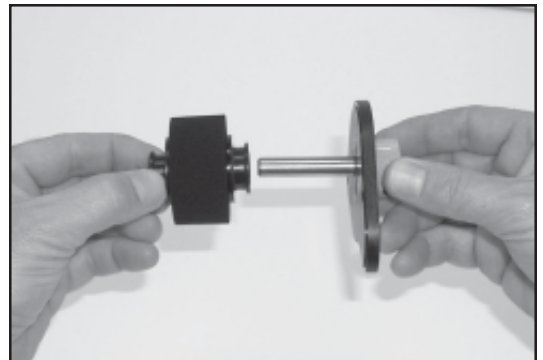

FIGURE 14

**10 - Hold the Inking System Cover Assembly in the proper orientation to fit back onto the Inking System Housing and carefully guide the Ink Roll into the large cavity.**

Try to avoid Ink Roll contact with the surface of the Transfer Roll during installation.



FIGURE 15

**11 - Replace the two cover retaining Thumbscrews.**



FIGURE 16

---

---

## QUICK START

---

---

### INSTALLING THE PRINTING DIES

Printing Dies can be installed on your new printer with the print drum in place or for more convenient installation, the print drum can be removed from the coder.

**1 - To remove the Print Drum from the coder, grip the Print Drum to prevent it from turning and remove the Print Drum Knurled Nut by rotating it counterclockwise.**



FIGURE 17

**2 - Lift the Print Drum off the Bearing Hub Assembly.**



FIGURE 18

**3 - Align the ribbed backing on the Printing Dies with the mating Print Drum covering and press firmly until they are completely engaged. It is best to install the dies as close to the middle of the print area on the Print Drum as possible.**

Individual character codes or text messages are installed in a mirror image of normal written text. In other words, install in a right to left direction as shown. When printed, codes or text installed in this orientation will print in normal left to right order.



FIGURE 19

To make die installation easier, moisten a sponge with water containing a small amount of liquid detergent. Lightly moisten the back of the printing die and then immediately press the die into the drum cover. Note: Do not apply too much liquid or the dies will slip during printing.

**Note: Do not apply silicone, oil or any other lubricating agent to the rib backing or the dies will not hold properly during printing. Some lubricants will permanently damage the Drum Covering and Printing Dies.**

---

---

## QUICK START

---

---

- 4 - When using the smaller individual characters to make up a code message, use the Type Blocking Kit included with your coder to support the leading and trailing ends of the type as shown.**

Characters with only a 2 or 3 rib backing do not have the stability of the larger sizes when snapped into the drum cover. Adding the rib backed type blocks on either side of the code will provide added stability. The Type Blocks are not as thick as the Type and will not pick up ink from the Transfer Roll.



FIGURE 20

- 5 - Reinstall the print drum on the Hub Assembly and replace the Print Drum Retaining Knob.**



FIGURE 21

### **ADJUSTING THE DIE POSITION ON INDEXING PRINTERS**

The print drums on indexing coders always return to the same rotational or “indexed” position after every print is applied and the print drum is lifted off the surface of the material being printed. In order to ensure that fresh ink is applied to the die faces on every printing cycle, the dies should be positioned rotationally upstream of the Transfer Roll when the print drum is in the indexed position.

- 1 - To position the printing dies, slightly loosen the Print Drum Knurled Nut. Rotate the Print Drum as necessary to bring the leading edge of the die into the position indicated and then hold the Print Drum stationary while tightening the Print Drum Knurled Nut to lock the Print Drum in place.**

When the printer is used with the leading edge of the printing die positioned as shown, the printing dies are immediately rotated past the anilox roll where the ink is applied and then the impression is immediately transferred to the surface of the material being printed.

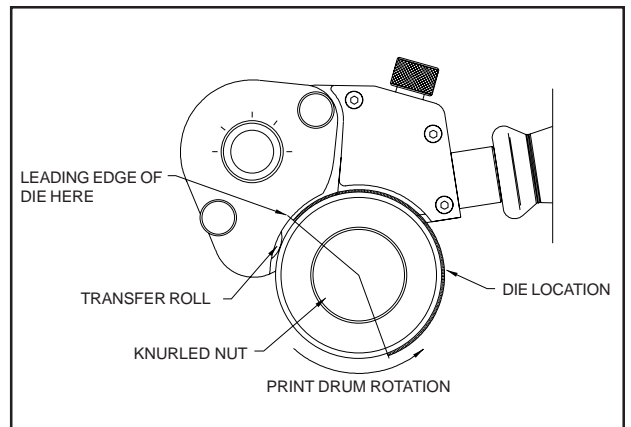

FIGURE 22

---

---

## QUICK START

---

---

### ADJUSTING THE INK ROLL ECCENTRIC

The Ink Roll is mounted on an axle which is position adjustable by rotating the Ink Roller Eccentric Adjusting Knob. This feature is designed to provide compensation for slight variations in Ink Roll diameters. With the Ink Roller Eccentric set at the "MIN" position, the Ink Roller will not make contact with the Anilox Roll. The position of the Ink Roll needs to be adjusted so that it makes adequate contact with the Anilox Roll in order for it to transfer ink properly. Too light a contact will result in the printing die not receiving enough ink to print and too heavy a contact will apply excessive ink to the printing die.

- 1 - To find the proper position for the Ink Roll, rotate the Eccentric Adjusting Knob from the "MIN" to the "1" position.



FIGURE 23

- 2 - Rotate the Print Drum and examine the face of the printing dies for signs of ink. If no ink has been applied to the die faces, rotate the Eccentric Knob a little more towards the "MAX" position. Repeat this procedure, examining the die faces each time, until the dies are fully coated with ink. Typically, the ink roll will make proper contact with the Anilox Roll when the Eccentric is near the "2" position.



FIGURE 24

- 3 - Apply a test print on a scrap of material and inspect the impression. Make further adjustments as necessary until a clear mark is applied with each test print. As soon as you are satisfied with the print quality, the unit is ready for production printing.



FIGURE 25

---

---

## **BASIC PRINCIPLES OF OPERATION**

---

---

Universal Hand Printers are in essence rotary rubber stamping machines. Applying text images from a flat printing die requires very uniform contact pressure and a very flat surface to transfer a good quality image. By wrapping a flat die around a print drum and applying the impression in a rolling motion greatly reduces the contact pressure required and minimizes the adverse affect of an irregular surface. An additional benefit of rotary stamping is the ability of the system to automatically apply ink to the die face in a very controllable method thus eliminating smudged impressions caused by over-inking.

Applying text images to non-porous surface such as metal, glass, rubber or plastic, requires the use of specially formulated inks which introduce an additional set of problems to the process. Understanding the mechanics of non-porous printing is essential to a successful operation and Universal's patented method of handling these special inks is the solution.

### **INKING SYSTEM DESIGN**

Inks designed for printing on non-porous surfaces contain very fast drying alcohol solvents, a component to impart color which can be either a liquid "dye" or a finely ground solid or "pigment", and a resin material which binds the color medium to the surface of the material being printed. When the printed marks are applied by the printer, the solvents evaporate rapidly from the printed impressions leaving only the dried resin and color.

Solvent base inks that evaporate rapidly at room temperatures to produce fast drying impressions will also evaporate rapidly from an ink pad or roll if it is exposed to atmosphere. Preventing rapid solvent loss from the inking system, which would cause the ink roll to dry out, has traditionally been a very difficult task. Universal's patented Non-Porous Inking System design has overcome this problem by enclosing all of the inking system components in a tightly sealed housing.

The two main components of the inking system as shown in Figure 26, are the Ink Roll and the Transfer or "Anilox" Roll. Both of these component parts reside in separate precision machined cavities in the Inking System Housing. When the Inking System Cover is installed, the minimal clearance between the Housing walls and the Anilox Roll surface provides an extremely small air channel for solvent vapor to escape. With this design the printers can be left idle for days with the ink rolls installed without adverse affect. The same ink roll left exposed to atmosphere would dry out in a matter of minutes.

The finely engraved surface of the Anilox Roll in this system also functions as an ink metering device. Applying a very thin film of ink to the face of the printing dies not only prevents smudged impressions caused by over-inking but it also reduces the drying time of the impressions by minimizing the amount of solvent being transferred.

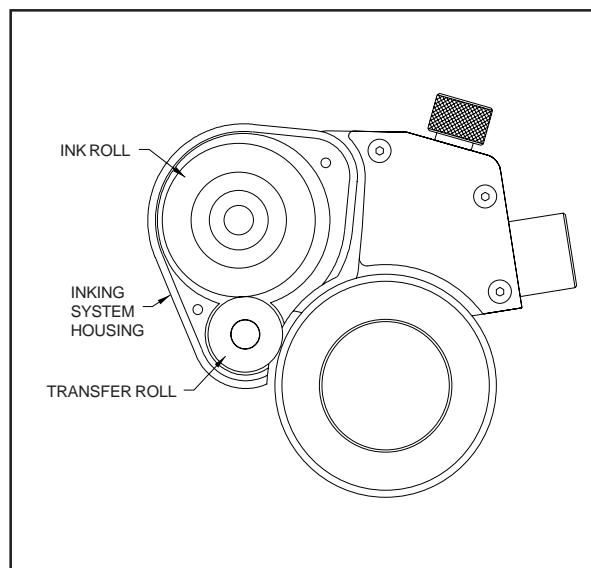

FIGURE 26

### **INK OPTIONS**

Although the standard #100 Inks are suitable for most non-porous printing applications, other alcohol base inks, including a variety of pigmented stencil inks, can be used in these coders. It is extremely important, however, to test the compatibility of the ink with the XF Neoprene Rolls. When fully saturated with ink, the Ink Roll must not exceed 2.030" diameter. MEK base inks are not compatible with the XF Neoprene Ink Rolls.

---

---

## MAINTENANCE

---

---

### PRE-INKING THE XF NEOPRENE INK ROLL

**Warning:** *Non-Porous Inks contain flammable solvents. Do not smoke or handle these rolls in the presence of sparks or open flames. Inks will also stain clothing, furniture, carpeting and your hands. Rubber gloves should be worn during the following procedures.*

A dry XF Neoprene ink roll has the same characteristics as a sponge with the capacity to absorb approximately 1 - 1.5 fluid ounces of ink. Please follow the guidelines below to properly pre-ink your roll

- 1 - Pour approximately 1-1/2 to 2 ounces of ink into a clean container.

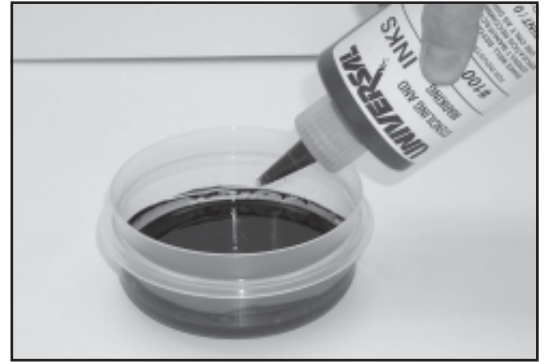

FIGURE 27

- 2 - Carefully place the roll into the container of ink. Using your finger tips, firmly press down on the side of the ink roll and then release the pressure. This will force the air out of the roll and the voids will be filled with ink. Turn the roll over, placing the un-inked side down in the container. Repeat the process above until the roller is fully saturated.

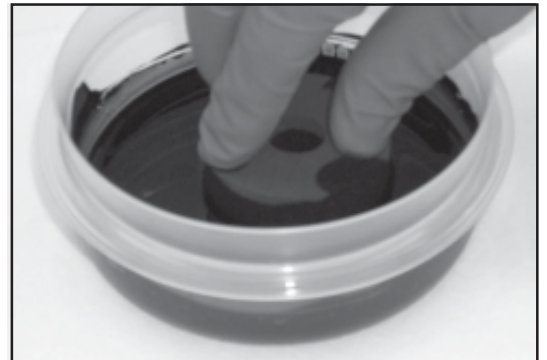

FIGURE 28

- 3 - Remove the Ink Roll from the container and place the roll on its side on a plastic bag or some other nonabsorbent surface. Push the Core into the center hole of the Ink Roll.



FIGURE 29

---

---

## **MAINTENANCE**

---

---

**4 - Using the Ink Roll Hub, push the Ink Roll fully onto the Core.**

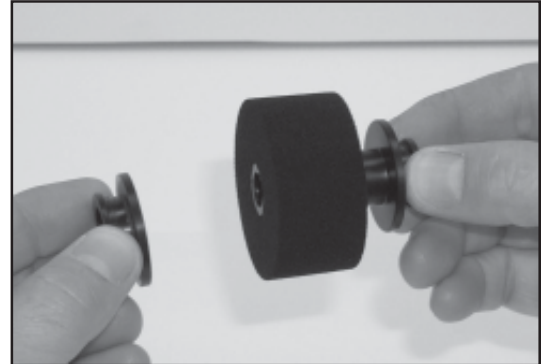

FIGURE 30

**5 - After the initial inking, the Ink Roll will be excessively wet. To remove the excess ink, place a round shank screwdriver through the core and roll the ink roll across a clean piece of paper or cardboard to remove excess ink.**

Installing an oversaturated ink roll on your coder will result in poor print quality and possible ink leakage problems.

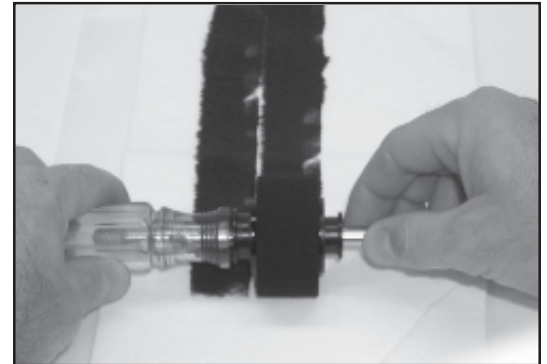

FIGURE 31

Your Ink Roll is now ready for use and should be installed on the coder immediately. If you are not ready to install the Ink Roll on the coder, it must be placed in a tightly sealed container for storage to prevent solvent evaporation. Leaving the roll exposed to atmosphere for even a short period of time will result in the roll drying out and may render it unusable.

---

---

## MAINTENANCE

---

---

### CLEANING THE PRINTING DIES

All inks which are formulated for printing on non-porous surfaces contain a resin binder which bonds the dye or pigment in the ink to the surface of the material being printed. As the ink begins to dry, this binder becomes “tacky” or “sticky”. While in this stage of the drying process, the tack on the dies will tend to pick up both airborne dust and any dust or dirt on the surface of the material being printed. After some period of use, the accumulation of contaminates on the dies will cause degradation of the print quality. When this happens, the dies should be cleaned or replaced. Cleaning the dies is a very easy process and, excluding excessive wear to the die face, will restore the print quality of the coder.

**The easiest method of cleaning Printing Dies requires the appropriate solvent for the ink being used, a pair of rubber gloves, safety glasses, an apron to protect your clothing is recommended, a toothbrush, some clean paper towels and a plastic bag to protect your workbench from staining. (Naturally, the toothbrush will never be suitable for oral hygiene use after this process.)**

- 1 - Place the contaminated Printing Die on top of several layers of paper towels to absorb the excess solvent. Pour just enough solvent on the face of the printing die to cover the die face.**

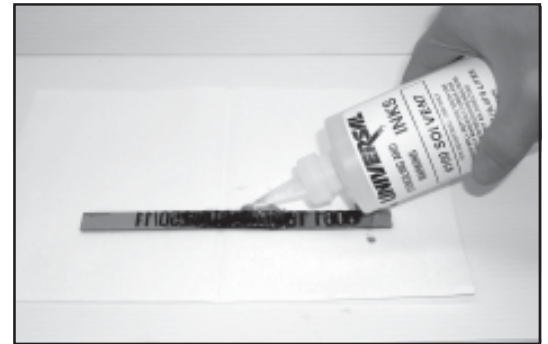

FIGURE 32

- 2 - Using the toothbrush, carefully scrub the face of the die to remove the contamination and old ink. Add more solvent as necessary and repeat the process until the die is clean.**

Do not submerge or soak the dies in solvent as this may cause swelling of the rubber compound.



FIGURE 33

- 3 - Blot the surface of the die with a clean paper towel to dry and reinstall the clean dies on the coder.**



FIGURE 34

---

---

## MAINTENANCE

---

---

### CLEANING THE TRANSFER ROLL

The surface of the transfer roll is made from DuPont Delrin material and the O.D. of the roll is finely engraved which enables it to hold a uniform film of ink. This surface material is very fragile and under no circumstances should you attempt to clean it with anything abrasive.

**Warning:** *Most of the ink solvents used for cleaning are flammable liquids. Follow all safety precautions recommended by the manufacturer during this process.*

- 1 -To clean dust and ink residue from the surface of the transfer roll, first remove it from the coder. Lightly saturate a soft cotton cloth with the appropriate ink solvent and gently rub the surface of the roll until it is clean.

If the ID of the Transfer Roll is contaminated with ink, the entire Transfer Roll can be submerged in solvent. A cotton swab may also be useful in cleaning hard to reach areas.

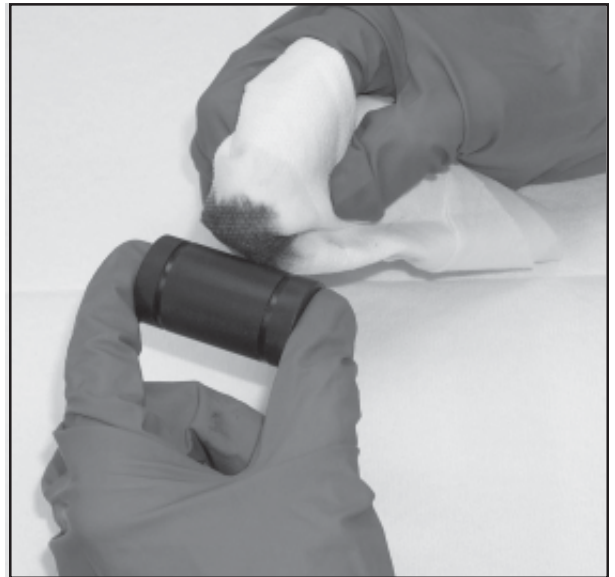

FIGURE 35

### CLEANING THE CODER

- 2 -Periodically, the inside of the Inking System Housing should be inspected for ink residue and dust contamination. To remove ink contamination from the surface of the machine, moisten a soft cotton cloth with the appropriate ink solvent and rub it across the contaminated area.

The frequency of required cleaning can be greatly reduced if the inking system is kept in proper adjustment during normal operation and if the ink roll does not become over saturated with ink.



FIGURE 36

---

---

# MAINTENANCE

---

---

## CODER ASSEMBLY NOTES

If for any reason, it becomes necessary to disassemble the entire printer, use the exploded parts diagram in the back of this manual for reference during reassembly. There are only 2 critical assembly instructions which require particular attention as follows:

### **ADJUSTING THE TRANSFER ROLL TO DIE FACE CONTACT PRESSURE**

When reinstalling the inking system housing on the printer frame, first install Pivot Screw "A". The Pivot Screw should be snug but not tight. Install Adjusting Screw "B" but leave it loose. With the Transfer Roll fully seated on its axle and the Print Drum properly installed, pivot the Inking System Housing towards the print drum until the surface of the Transfer Roll makes positive contact with the Friction Bearers on the Print Drum. The contact pressure should be just enough to positively drive the Transfer Roll when the Print Drum is rotated. When the proper position has been reached, tighten Screw "B" and then Screw "A". Rotate the Print Drum to ensure the Transfer Roll is rotating.

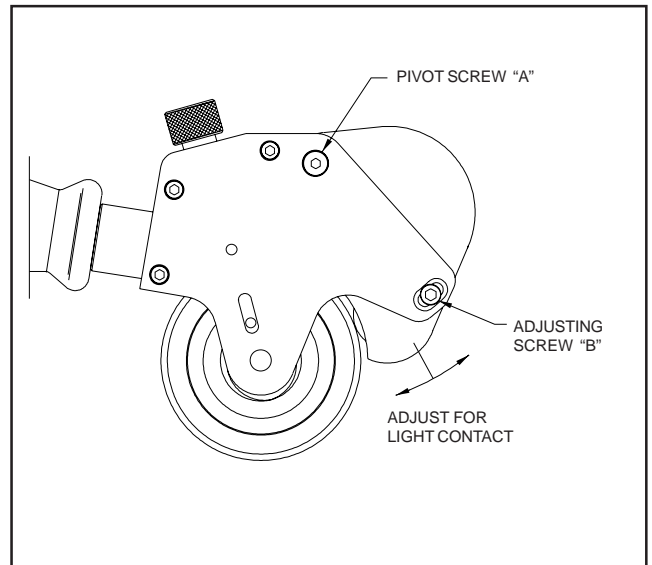

FIGURE 37

In operation, when the Print Drum is rotating, the rubber Friction Bearers on the Print Drum must positively drive the Transfer Roll. The amount of engagement pressure exerted at the contact point between these two components is adjustable by moving the position of the Inking System Housing. If the contact pressure is too light, the Transfer Roll will not rotate and no ink transfer will occur. If the contact pressure is excessive, it will cause too much drag on the Print Drum and the Index Mechanism will not operate properly.

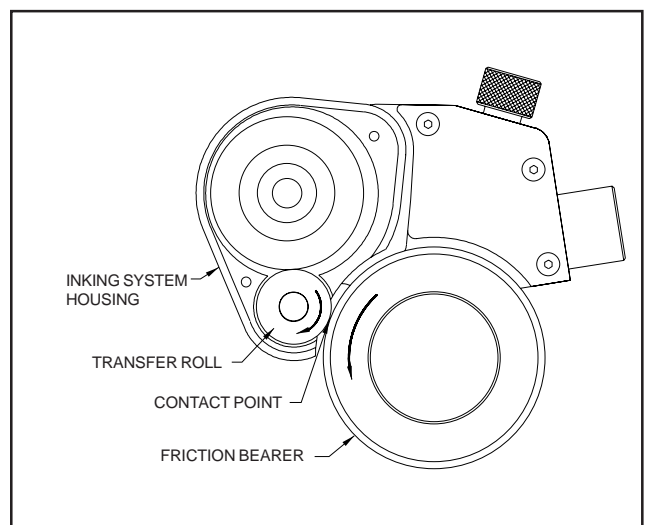

FIGURE 38

---

---

## MAINTENANCE

---

---

### INSTALLING THE INDEX ASSEMBLY

All of the Non-Porous Hand Printers are machined to accommodate an Indexing Assembly. If you have a Non-Indexing model, an Index Conversion Kit can be ordered to convert the unit to an Indexing Model. The following steps will guide you through the installation process.

**1 - Remove the Print Drum and Frame Side Cover to expose the Coder Frame.**



FIGURE 39

**2 - Apply a light coating of grease to the bottom and sides of the Index Slide Bracket.**

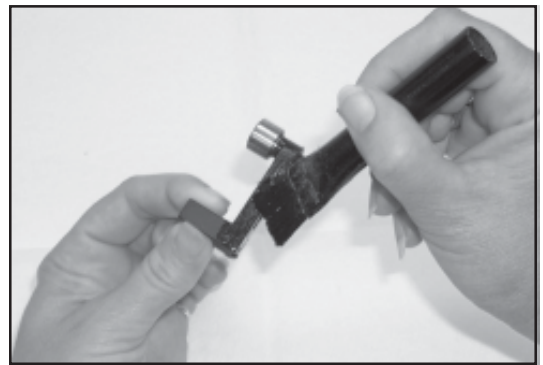

FIGURE 40

**3 - Place the Index Slide Assembly into the milled slot in the Frame with the Cam Roller Bearing end towards the Print Drum Bearing Hub.**



FIGURE 41

**4 - Place the small plastic washer on the Index Slide Screw. Apply a drop of removable thread locking compound such as Loctite #222 on the first few threads of the screw.**



FIGURE 42

---

---

## **MAINTENANCE**

---

---

- 5 - Install the screw and washer assembly and tighten fully, then loosen the screw approximately 1/8 turn to allow the slide to move.**

Test the motion of the Index Slide by moving it back and forth in the slot. It should move freely but must be held securely in the slot by the washer and screw. If necessary, tighten and loosen the screw a second time to compensate for the displacement of any excess grease.

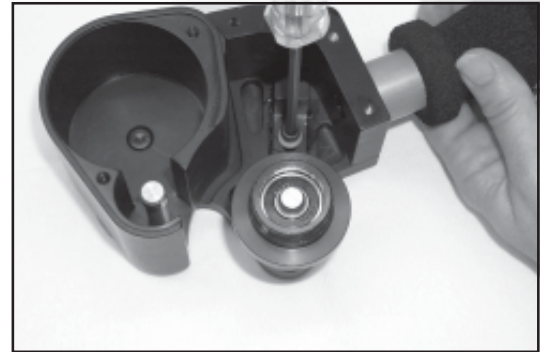

FIGURE 43

- 6 - Install the Index Spring by inserting it through the hole in the Back Frame.**

The end of the spring must locate in the round hole in the Index Slide.

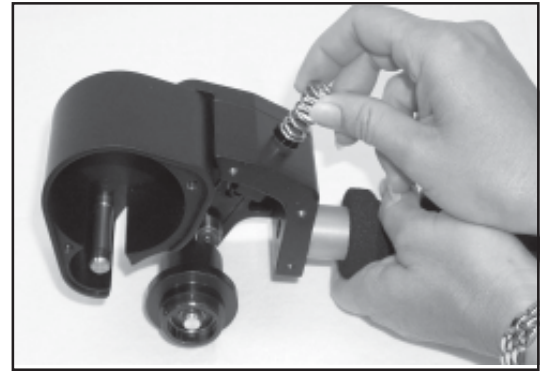

FIGURE 44

- 7 - Install the Tension Adjusting Knob in the threaded hole in the Back Frame.**

Applying a light coating of grease to the threads of the Tension Adjusting Knob is recommended.

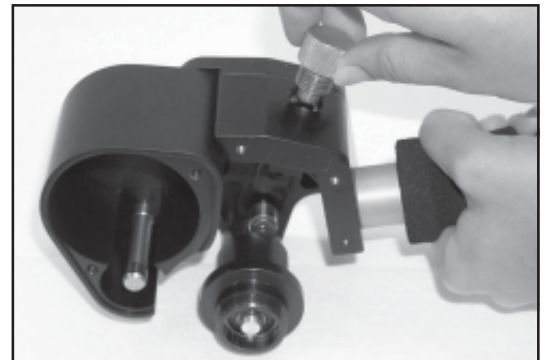

FIGURE 45

- 8 - Reinstall the Frame Side Cover, the Print Drum and the Ink Roll and the coder is ready for use.**



FIGURE 46

# NON-POROUS HAND PRINTER ASSEMBLY

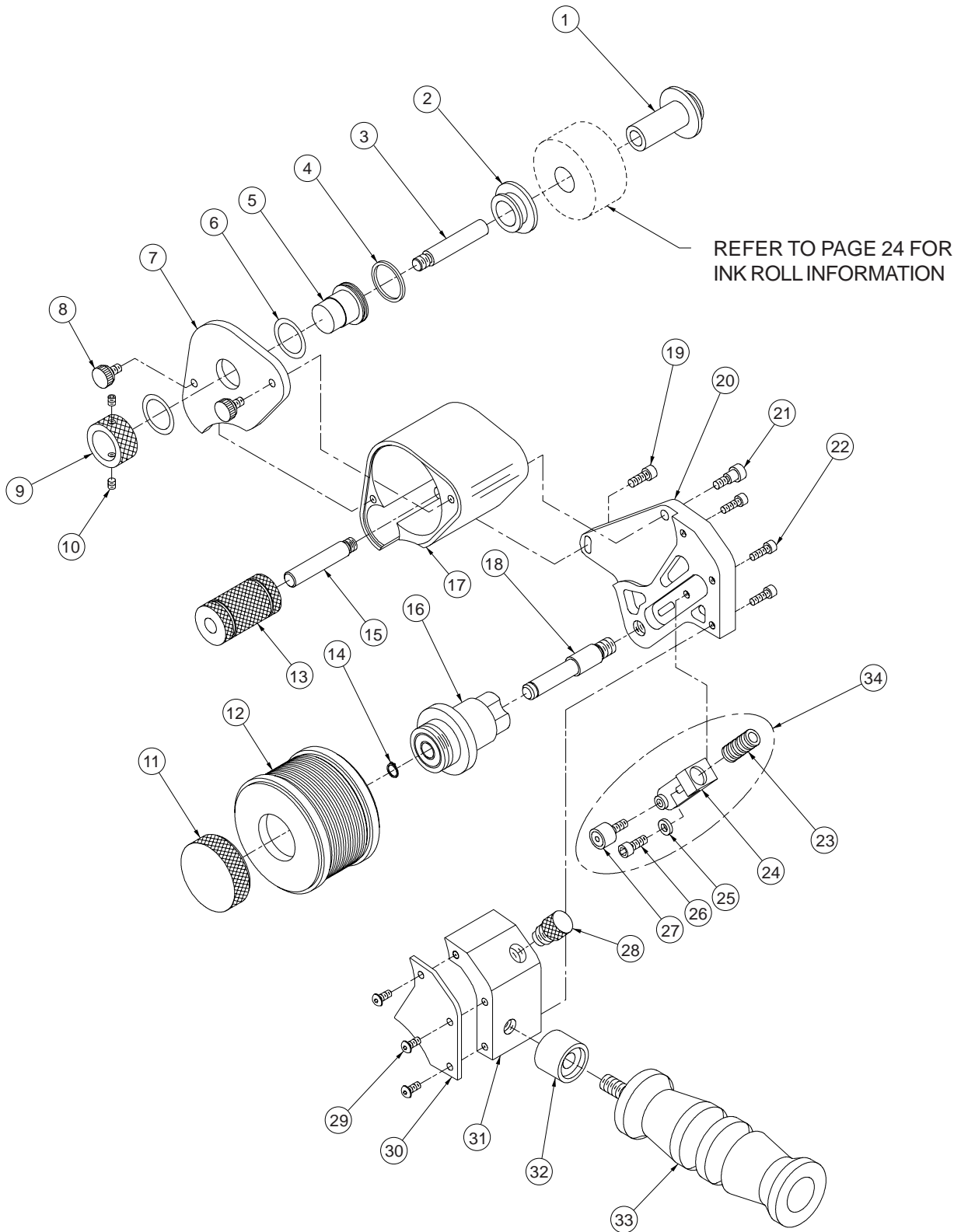

## NON-POROUS HAND PRINTER PARTS LIST

| KEY NO. | PART NUMBER    | QTY. REQD. | DESCRIPTION                            |
|---------|----------------|------------|--|
| 1       | HPN-027        | 1          | ROLLER CORE                            |
| 2       | HPN-028        | 1          | ROLLER HUB                             |
| 3       | HPN-001        | 1          | AXLE, INK ROLL                         |
| 4       | NP-21          | 1          | O-RING, ECCENTRIC                      |
| 5       | HPN-007        | 1          | ECCENTRIC                              |
| 6       | HP-42          | 2          | DELTRIN WASHER                         |
| 7       | HPN-019        | 1          | INKING SYSTEM HOUSING COVER            |
| 8       | HPNP-TSA       | 2          | THUMB SCREW ASSEMBLY                   |
| 9       | HPN-008        | 1          | ECCENTRIC KNURLED KNOB                 |
| 10      | HP-06          | 2          | SET SCREW, 8-32 X 3/16" CPS            |
| 11      | HPN-022        | 1          | KNURLED NUT, PRINT DRUM                |
| 12      | HPNP-100-PDA   | 1          | PRINT DRUM ASSEMBLY - STANDARD         |
|         | HPNP-100-PDA-T |            | PRINT DRUM ASSEMBLY - METRIC           |
| 13      | HPN-004        | 1          | TRANSFER ROLL, NON-POROUS HAND PRINTER |
| 14      | HPN-023        | 1          | SNAP RING FOR 3/8" SHAFT               |
| 15      | HPN-020        | 1          | TRANSFER ROLL AXLE                     |
| 16      | HPNP-BHA       | 1          | BEARING HUB ASSEMBLY                   |
| 17      | HPN-018        | 1          | INKING SYSTEM HOUSING                  |
| 18      | HPN-002        | 1          | AXLE, PRINT DRUM                       |
| 19      | CF-29          | 1          | SCREW, 10-32 X 1/2" SHC                |
| 20      | HPN-005        | 1          | FRAME                                  |
| 21      | HPN-029        | 1          | FRAME HOUSING SHOULDER SCREW           |
| 22      | MS-36          | 3          | SCREW, 8-32 X 1/2" SHC                 |
| 23      | HPN-026        | 1          | INDEX SPRING                           |
| 24      | HPN-013        | 1          | INDEX SLIDE BRACKET                    |
| 25      | HPN-015        | 1          | INDEX SLIDE DELTRIN WASHER             |
| 26      | HPN-014        | 1          | SCREW, 10-32 X 5/8" SHC                |
| 27      | CB-06          | 1          | BEARING, CAM ROLLER                    |
| 28      | HPN-016        | 1          | TENSION ADJUSTING KNOB                 |
| 29      | MS-33          | 3          | SCREW, 8-32 X 3/8" BHS                 |
| 30      | HPN-006        | 1          | FRAME SIDE COVER                       |
| 31      | HPN-017        | 1          | BACK FRAME                             |
| 32      | HP-17          | 1          | BUSHING, HANDLE                        |
| 33      | HPNP-HA        | 1          | HANDLE ASSEMBLY                        |
| *34     | HPNP-ICA       | 1          | INDEXING CONVERSION ASSEMBLY - HPNP    |

\*INDEXING CONVERSION ASSEMBLY TO CONVERT NON-INDEXING MODELS TO INDEXING

## NON-POROUS HAND PRINTER PRINT DRUM ASSEMBLY PARTS LIST

| KEY NO. | PART NUMBER | QTY. REQD. | DESCRIPTION                        |
|---------|-------------|------------|------------------------------------|
| 1       | MC-01S      | 2          | O-RING, P.D. BEARER, SQUARE CUT    |
| 2       | MC-43       | 1          | RIBtype® RING 1-1/8" MC - STANDARD |
|         | MC-43T      |            | RIBtype® RING 1-1/8" MC - METRIC   |
| 3       | HPN-003     | 1          | PRINT DRUM - STANDARD              |
|         | HPN-003T    |            | PRINT DRUM - METRIC                |

## NON-POROUS HAND PRINTER PRINT DRUM & CORE ASSEMBLY

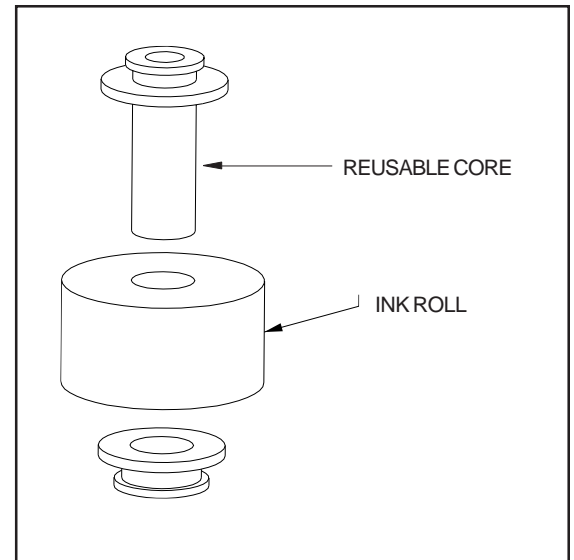
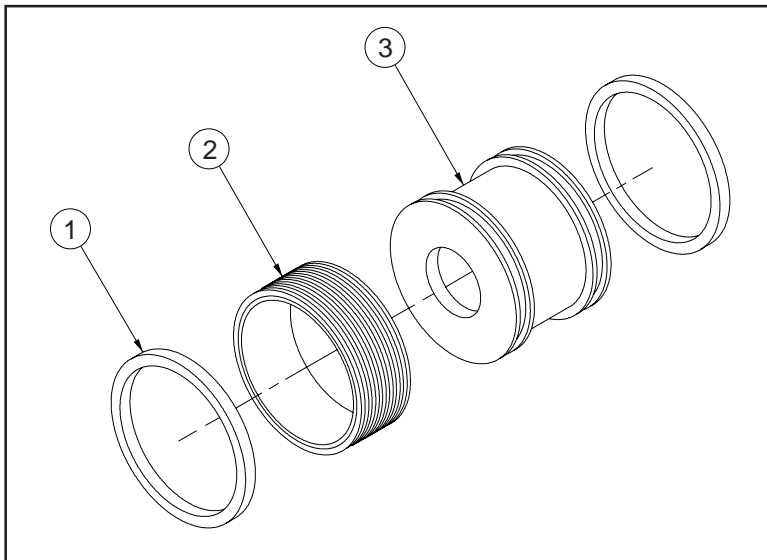

## NON-POROUS HAND PRINTER REPLACEMENT INK ROLLS

| DISPOSABLE TYPE MT INK ROLLS   |  |
|--|--|
| PART NUMBER  | DESCRIPTION                                    |
| HPNP-MT1-P1  | NON-POROUS HAND PRINTER MT ROLL - BLACK        |
| RE-INKABLE - XF NEOPRENE INK ROLLS   |  |
| <p><b>IMPORTANT!</b> The core supplied with the Non-Porous Hand Printer is <i>reusable and should not be discarded with the roll sleeve.</i><br/>                     The XF Neoprene <i>Replacement Ink Rolls are sleeves only and are sold separately.</i></p> |  |
| PART NUMBER  | DESCRIPTION                                    |
| HPNP-100RX   | 1" XF NEOPRENE REPLACEMENT SLEEVE              |
| HPNP-100RX-P1  | 1" XF NEOPRENE REPL. SLEEVE - PRE-INKED BLACK  |
| HPNP-100RX-P2  | 1" XF NEOPRENE REPL. SLEEVE - PRE-INKED RED    |
| HPNP-100RX-P3  | 1" XF NEOPRENE REPL. SLEEVE - PRE-INKED GREEN  |
| HPNP-100RX-P4  | 1" XF NEOPRENE REPL. SLEEVE - PRE-INKED BLUE   |
| HPNP-100RX-P5  | 1" XF NEOPRENE REPL. SLEEVE - PRE-INKED YELLOW |
| HPNP-100RX-P6  | 1" XF NEOPRENE REPL. SLEEVE - PRE-INKED WHITE  |
| HPNP-100RX-P9  | 1" XF NEOPRENE REPL. SLEEVE - PRE-INKED VIOLET |

