

Non-Porous Hand Printer

U.S. PATENT NO. 5,109,769 E.P. PATENT NO. 0508971

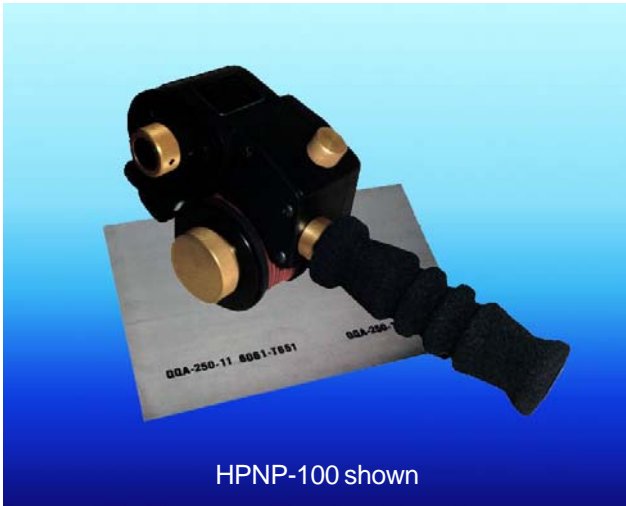

Universal's Non-Porous Hand Printer fills the requirement for a portable, hand held roll coder designed for marking on metal, plastic, glass, rubber and other materials that require fast drying solvent based inks.

The unique technology of our patented Non-Porous Inking System allows the usage of inks that dry as fast as 2 seconds at 75 degree F. ambient temperatures. This unique system utilizes both an ink roll and an engraved anilox roll to apply ink to the rubber printing dies. The rolls are mounted in a tightly sealed aluminum housing which prevents solvent evaporation from the ink roll during use.

The print drum's cam indexing mechanism provides for accurate print registration on smaller parts or the unit can be used in a non-indexing, continuous print mode for printing long lengths of material such as metal sheets.

Precision machined from aircraft grade aluminum alloy, these coders are ideal for printing specifications, lot numbers, date codes or product identification information on any flat, non-porous surface. The high quality impressions are both weather proof and fade resistant and can be applied at rates much faster than stenciling or conventional hand stamping.

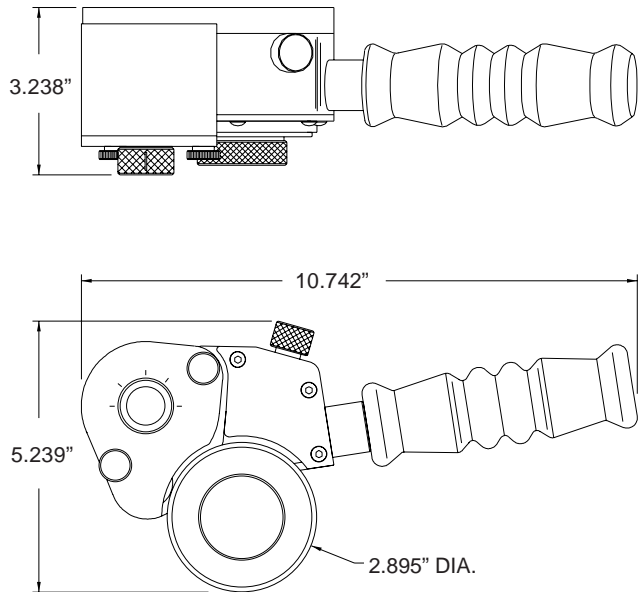

FEATURES

- Precision machined anodized aluminum construction
- Sealed ball bearings for smooth print drum rotation
- Comfortable foam grip handle
- Easily removable print drum simplifies type setting
- Indexing or Non-Indexing capabilities

SPECIFICATIONS

HPNP-100 Indexing Model
HPNP-100NI Non-Indexing Model
Print Drum Circumference: 9.1" (227 mm)
Maximum Print Width: 1.0" (25 mm)
Die System: RIBtype® rubber type
Weight: 2 Lbs - 12.5 Oz. (1.26 Kg)

The HPNP Hand Printers are supplied with one of Universal's disposable Type MT Black Ink Rolls. For maximum versatility, the inking system also accommodates a re-inkable XF Neoprene Ink Roll. RIBtype® rubber type characters and / or logo dies are sold separately.

Manufactured By
Universal Stenciling & Marking Systems, Inc.

P.O. Box 871 - St. Petersburg, FL 33731 - U.S.A.

Ph: (727) 894-3027 Fax: (727) 821-7944 E-Mail: sales@universal-marking.com Website: www.universal-marking.com